

Culvert Crossings

Introduction

Stream crossings are a common feature of farm access, and on small streams often take the form of a culvert pipe set in an earth embankment. This type of crossing can carry heavy loads and will require little maintenance if constructed properly. Depending on the required pipe size construction of culverts can be carried out as a permitted activity (i.e. will not require a resource consent) if certain conditions are met. For more information see **Sustainable Options LM05 Stream Crossings**, and consult the Bay of Plenty Regional Land Management Plan.

Design Factors

Under Environment Bay of Plenty Land Management rules, culvert pipes must be large enough to handle the flow produced by a storm event with a 10 year return period. The actual volume of flow will depend on the local rainfall intensity of such an event, the area of catchment on which it occurs, the gradient, soil type and land cover of that catchment. These factors are processed through a set of specialised equations to determine what pipe size (diameter) will be required.

Engineering consultants and Environment Bay of Plenty can provide such information as a contract design service.

Culvert pipes must be a minimum 300 mm internal diameter, and if more than a 900 mm diameter pipe is needed to accommodate a 10 year (return period) flood flow, a resource consent will be required for the crossing.

Culvert embankments are not intended to act as dams, but where high debris load accumulates during flood flows, culvert pipes can get blocked and flow then overtops the structure. Overtopping presents a serious risk to the embankment because concentrated flow over the downstream face can scour out large holes and cause partial collapse of the structure.

To avoid this possibility incorporate a spillway into the embankment design. Spillways need to be of adequate size (cross-sectional area) and should be constructed on undisturbed ground. Select crossing sites where this will be possible and also where there is a firm streambed to prevent excessive settling of the culvert pipe.

Embankment sides should be battered (sloped) for stability. Gentle slopes will be more stable than steep slopes and the maximum recommended batter gradients for culvert embankments are 2:1 (upstream side) and 3:1 (downstream side). Batters should be sown with seed of suitable ground cover (grass and legume) species immediately after construction, preferably in the autumn.

Length of pipe should be adequate to allow both ends to protrude clear of the embankment, otherwise headwalls will be necessary. Headwalls can reduce the length of pipe required in wide embankments and can be used where embankment batters are constrained by tightly meandering stream beds or steep channel gradients.

Construction Techniques

To minimise soil disturbance and cost, use an excavator for site preparation and placement of pipes. Stockpile surplus soil well clear of stream channels. Lay culvert pipes on a minimum gradient of 2° (i.e. 28:1) and compact backfill around pipes. Pay particular attention to compacting backfill around the lower sides of the pipe to prevent excessive settling and failure under load. Ensure there is an adequate depth of fill over the pipe – the recommended minimum is 800 mm. The maximum fill height over a culvert pipe is 1.5 m for construction as a permitted activity. If fill height is going to exceed this limit a resource consent will be required.

Build up the embankment with 200 mm soil layers, compacting each layer. Use only clean fill for embankment construction i.e. do not use material containing vegetation and woody slash, car bodies, plastic containers or other refuse. Shape batters to the correct gradient, oversow with a grass legume seed mix and lightly work this in with harrows if possible (see **Sustainable Options LM13 Plant Selection for Disturbed Sites**).

Item	Size	Material
Piles	200 mm diameter x 3 m length	Radiata pine H5
Walling	200 mm x 50 mm	Radiata pine H5
Tie Back Cable	15 mm diameter	Wire rope
Anchor Blocks	100 mm x 100 mm x 1.8 m post or 150 mm x 1.8 m half round post	Concrete Radiata pine H4

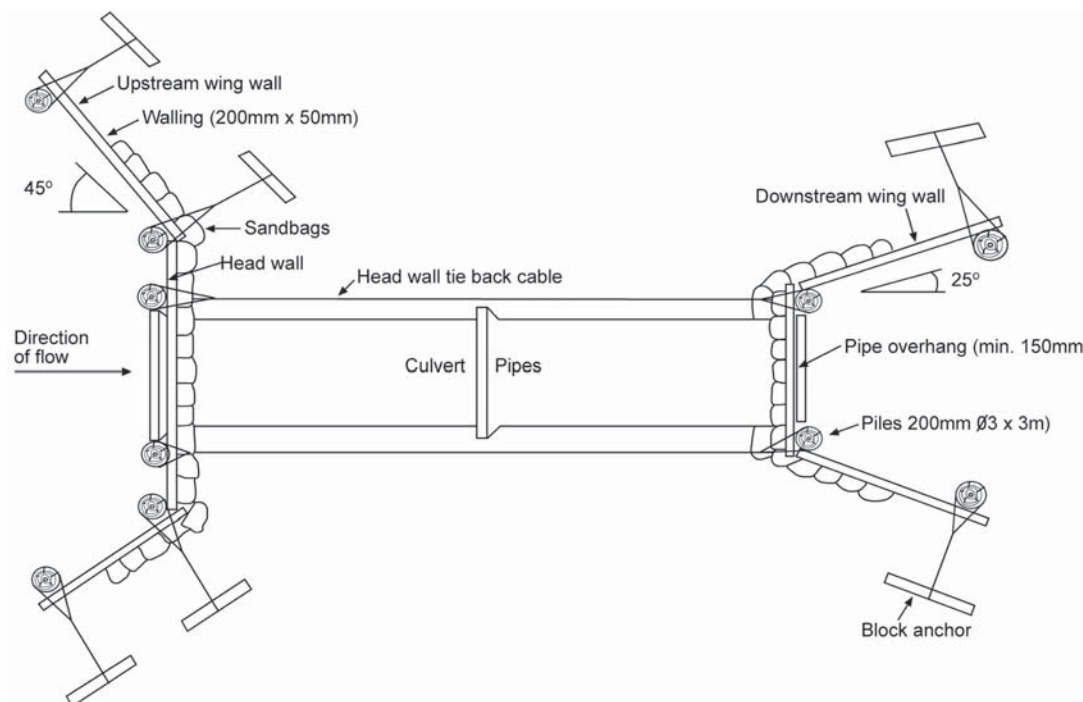

Headwall Materials

For specifications regarding constructing of headwalls, refer to the diagram above and the table overleaf. Use round wood for piles. Drive piles at least 1 metre into undisturbed ground and space piles no further apart than 2.5 m. Tie back all piles.

Tie headwall piles back to those on the opposite side of the crossing. Pre-tension piles with the aid of a ratchet tiedown strap when installing the tie back cables to eliminate slack in the fitted cables. Tie wing wall piles back to anchor blocks in the fill slope. Use two clamps for each cable loop.

Do not back fill soil directly against walling. Sandbag these zones using a dry mix of sand and cement (4:1), especially where pipes emerge from head walls. The use of sandbags will prevent fine soil material washing out and thereby undermining the embankment.

A single row wall of sandbags is required to the full height and length of headwalls. For wing walls a single row stack to the full height and half the length of the wall is generally sufficient.

General

Control any runoff that may flow onto the embankment from elevated sections of track on either side of the crossing. If storm water flow is allowed to cross fill slopes it can scour embankments and threaten structural stability. Use cut-off drains on the crossing approaches to divert track runoff onto undisturbed (and vegetated) ground.

When constructing crossings of any kind, it is recommended that qualified, experienced contractors be used. Remember that poorly designed and built crossings are ultimately very expensive because of the amount of maintenance and repair work they require. Poorly built crossings also have an adverse

effect on water quality and landowners risk prosecution if construction is in breach of the Regional Land Management Plan and the Resource Management Act (1991).



For further information and advice, contact your local soil conservator at Environment Bay of Plenty:

Telephone: 0800 ENV BOP (368 267)
 Facsimile: 0800 ENV FAX (368 329)
 Pollution Hotline: 0800 73 83 93
 Email: info@envbop.govt.nz
 Website: www.envbop.govt.nz
 Address: 5 Quay Street, P O Box 364, Whakatane, New Zealand

This fact sheet was prepared by John Douglas

This fact sheet was last updated July 2004