



---

**Nitrogen exports from the Lake  
Rotorua catchment – calibration of the  
ROTAN model**

---

**NIWA Client Report: HAM2009-019  
January 2009 Revised April 2009**

**NIWA Project: BOP08225**

---

## **Nitrogen exports from the Lake Rotorua catchment – calibration of the ROTAN model**

---

**Kit Rutherford  
Chris Palliser  
Sanjay Wadhwa**

*Prepared for:*

**Environment Bay of Plenty**

NIWA Client Report: HAM2009-019  
January 2009 Revised April 2009

NIWA Project: BOP08225

**National Institute of Water & Atmospheric Research Ltd**

Gate 10, Silverdale Road, Hamilton  
P O Box 11115, Hamilton, New Zealand  
Phone +64-7-856 7026, Fax +64-7-856 0151  
[www.niwa.co.nz](http://www.niwa.co.nz)

# Contents

---

Executive Summary	iv
1. Introduction	1
2. Background	2
3. Agricultural statistics	16
4. Nitrogen inputs	21
5. Nutrient predictions	33
6. Discussion and conclusions	52
7. Acknowledgements	53
8. Appendix 1: Rules for predicting land use from land cover	54
9. References	60

---

*Reviewed by:*



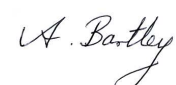
Neale Hudson

*Approved for release by:*



Max Gibbs

*Formatting checked*



## Executive Summary

The ROTAN model has been calibrated for the Lake Rotorua catchment and a satisfactory fit achieved to: (1) the long-term water balance, (2) previously published estimates of nitrogen input to the lake and (3) measured TN concentrations in the major streams.

GIS maps of land use/cover for 1940, 1958, 1986, 1996, 2001 and 2003 were used in this study. No map was available for the 1970s – a period of land use intensification – and it is desirable to incorporate such a map. Land use is only described for 1958 and 2003 and there are uncertainties in estimating land use from land cover in 1986, 1996 and 2001.

Agricultural statistics for the Rotorua district were used to estimate: (1) land use from land cover and (2) stocking rates. These data were then used in Overseer® ([www.agresearch.co.nz/overseerweb](http://www.agresearch.co.nz/overseerweb)) to estimate nitrogen export rates. No allowance was made for changes in animal weight during the study period although significant increases in carcass weight occurred from 1985-2005.

ROTAN simulations in this report use the Phase 7 GNS external aquifer boundaries which give a satisfactory water balance for the lake. There are differences in the internal boundaries between ROTAN and Phase 7 GNS but these are unlikely to have a significant effect on predicted total nitrogen input.

Aquifer parameters were selected to match groundwater mean residence times (MRTs) reported by Morgenstern & Gordon (2006).

The match between observed and predicted nitrogen concentrations in the major streams, and between total input to the lake and previously published estimates, are both satisfactory. The earliest stream measurements used were from 1976-1977 (Hoare 1980) and ROTAN simulations cannot be verified prior to the 1970s.

Predicted nitrogen concentrations in the major streams are sensitive to uncertainties in aquifer boundaries, land use history, stocking rate history, and MRT – further work is desirable to refine current estimates of aquifer boundaries and land use history.

The simulations in this report assume zero attenuation. The satisfactory match obtained indicates that either nitrogen exports have been under-estimated and attenuation is non-zero, or that nitrogen exports have been estimated correctly and attenuation is negligible.

ROTAN can now be used to forecast likely changes in lake nitrogen input for different scenarios of land use and mitigation measures.

## 1. Introduction

NIWA was contracted by Environment Bay of Plenty (EBoP) to use the catchment-scale model ROTAN (ROtorua and TAupo Nitrogen model) to aid the restoration of lakes Rotorua and Rotoiti. An earlier report describes the ROTAN model and outlines calibration of its hydrology component (Rutherford et al. 2008). This report describes the re-calibration of the hydrology component and calibration of the nitrogen component. The report makes extensive use of information about aquifer boundaries from GNS investigations (White et al. 2004, 2007; Morgenstern & Gordon 2006).

Baseflow nitrate concentrations in major streams draining into Lake Rotorua increased significantly over the period 1968-2003 (Rutherford 2003). As a result the nitrogen input to Lake Rotorua from streams is now significantly higher than the 'target' input set for the lake. There is no apparent increase in baseflow soluble phosphorus concentration or load.

Groundwater in some parts of the catchment is several decades old (Stewart and Morgenstern 2001). There was a period of land clearance in the 1940s and it has been hypothesised that current trends in stream concentration are the effects of historic land use changes making their way slowly through the groundwater (Williamson et al. 1996). Recent land use intensification may be contributing to lake inputs where groundwater lags are small, and this contribution will increase in the future.

Strategies for lake restoration include land use change and measures to reduce nitrogen exports from farmland. EBoP requires effective tools for predicting the cumulative effect of land use change and mitigation measures on nutrient inputs to the lakes. Two challenges for managers are: (1) to determine which properties contribute diffuse nitrogen via runoff to the lake, given that the boundaries of aquifers draining to the lake may not coincide with the boundaries of the surface catchment; and (2) to predict how quickly reductions of nutrient export from different parts of the catchment will reduce inputs to the lakes, given the groundwater lags in the system.

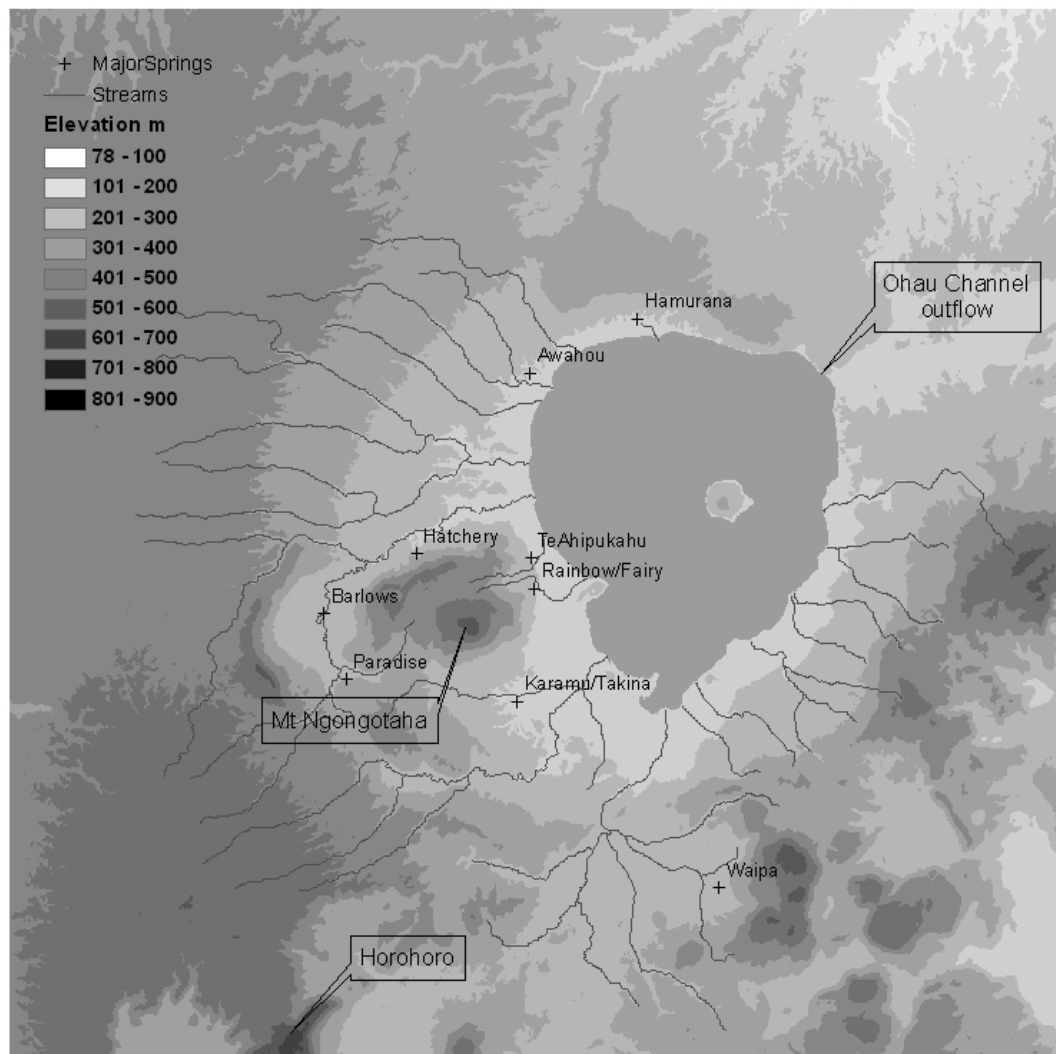
Steady-state estimates of the effects of land use change and mitigation could be made using the CLUES model ([www.maf.govt.nz/mafnet/rural-nz/sustainable-resource-use/clues/stage-2/page-06.htm](http://www.maf.govt.nz/mafnet/rural-nz/sustainable-resource-use/clues/stage-2/page-06.htm)), but CLUES currently does not include groundwater lags. Morgenstern and Gordon (2006) have estimated the effects of a step change in land use just after WWII including predictions of the 'loads to come'. This report aims to complement Morgenstern and Gordon (2006) by simulating temporal and spatial variations in rainfall, infiltration, land use and nitrate leaching.

## 2. Background

### Nitrogen and water quality

Lake Rotorua is important for recreation and tourism, and deteriorating water quality has been a concern since the 1960s (Rutherford et al. 1989). Short-term bioassays indicate that the lake is nitrogen limited (White et al. 1977), although recent studies (Burger et al. 2007) indicate that phosphorus limitation is beginning to occur. Nitrate concentrations in streams draining into Lake Rotorua have increased significantly over the period 1968-2003 (Rutherford 2003) and this trend is believed to have contributed to recent poor lake water quality. It has been hypothesised that current trends in stream nitrate concentration are the result of land use intensification in the 1940s making their way slowly through the groundwater (Williamson et al. 1996; Morgenstern and Gordon 2006). However, further land use intensification has occurred in recent years and this may also be contributing to nitrogen inputs to the lake.

The geology of the Rotorua catchment is complex. Three separate ignimbrite layers have been identified which are punctured in several places by rhyolite domes, while the lake shores comprise sedimentary rocks (White et al. 2004). Groundwater aquifers occur in all three formations. The Lake Rotorua catchment contains several large springs fed by groundwater. Pang et al. (1996) identified 10 groups of springs with a total flow of  $6.5 \text{ m}^3 \text{ s}^{-1}$  (32% of lake inflow) the largest being Hamurana ( $2.7 \text{ m}^3 \text{ s}^{-1}$ ), Awahou ( $1.7 \text{ m}^3 \text{ s}^{-1}$ ) and Rainbow/Fairy ( $0.3 \text{ m}^3 \text{ s}^{-1}$ ) (Figure 1). Dating using tritium has shown that spring and stream water varies in age from 15-170 years (Stewart and Morgenstern 2001; Morgenstern et al. 2005; Morgenstern and Gordon 2006). Geothermal springs in the lakebed have been identified in shallow water on the south and south-eastern shoreline (John and Lock 1977) and there may be other geothermal and coldwater springs elsewhere in the lake.



**Figure 1:** Catchment map showing the main streams, the outflow and major springs.

### Water balance

Stream flow measured at the outlet of a catchment does not always match runoff calculated as the difference between rainfall and evapotranspiration because of groundwater gains or losses. This situation is common throughout the world and occurs where the underlying geology is anisotropic and inhomogeneous as a result of dissolution by water, fracturing or layering. Where this occurs, aquifer boundaries do not match the boundaries of surface (topographic) catchments and specific yields (flow divided by surface catchment area) vary spatially. In such situations it is difficult to calibrate models of nutrient runoff and delivery to downstream lakes. It is especially difficult to determine which properties located near the catchment boundaries contribute nutrient to the lake.

Rutherford et al. (2008) used the GIS-based catchment model ROTAN to study the water balance of the Lake Rotorua catchment. They found that in order to achieve a water balance for Lake Rotorua it was necessary to postulate that groundwater from land outside the surface catchment drains into the lake. They concluded that the ‘most likely’ estimate of the area of the additional catchment was 60 km<sup>2</sup> based on pasture actual evapotranspiration (AET) = 800 mm, forest AET = 1100 mm, rainfall under-catch = 5% and rainfall interpolation error = 5%. The estimate of 60 km<sup>2</sup> for the ‘extra’ catchment area is very similar to the estimate made by White et al. (2007) although the two are based on different rainfall and evapotranspiration data.

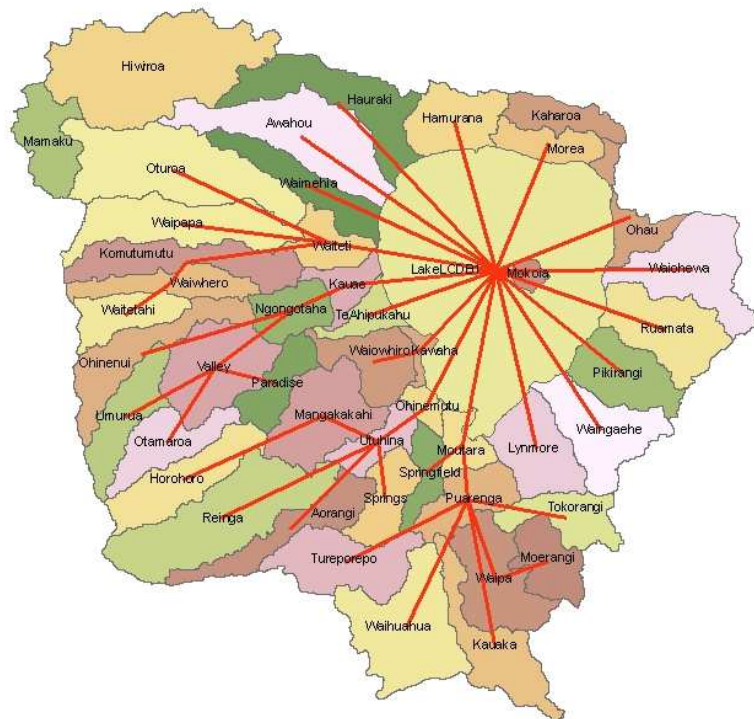
The 2008 study has important implications for nutrient management because it showed there is a fairly large area of land outside the boundary of the surface catchment contributing water and nutrients to the lake. The location of this additional catchment is uncertain. Although the ‘most likely’ additional area is 60 km<sup>2</sup> it could range from 5-80 km<sup>2</sup>.

### **Model description**

ROTAN is a daily time-step, conceptual rainfall-runoff-groundwater model. The model runs within ArcGIS using Microsoft Access® databases. Details of the model are given elsewhere (Rucinski et al. 2006).

Catchments are defined using the River Environment Classification (REC) stream network system ([www.niwascience.co.nz/ncwr/rec](http://www.niwascience.co.nz/ncwr/rec)). Catchments used in the simulations reported here are shown in Figure 2. In the larger catchments (e.g., Ngongotaha, Utuhina and Puarenga) there are several sub-catchments connected by stream channels, but smaller catchments are not sub-divided. Catchments outside the boundaries of the lake catchment (e.g., Hiwiroa and Mamaku) contain streams that flow to the north west and do not enter the lake, but deep drainage in these catchments enters groundwater that eventually flows into the lake.

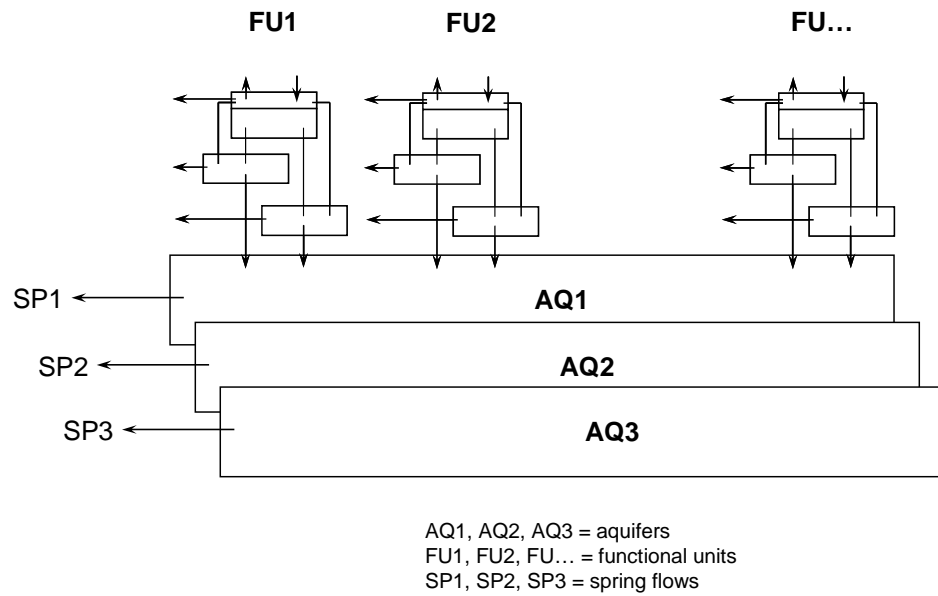
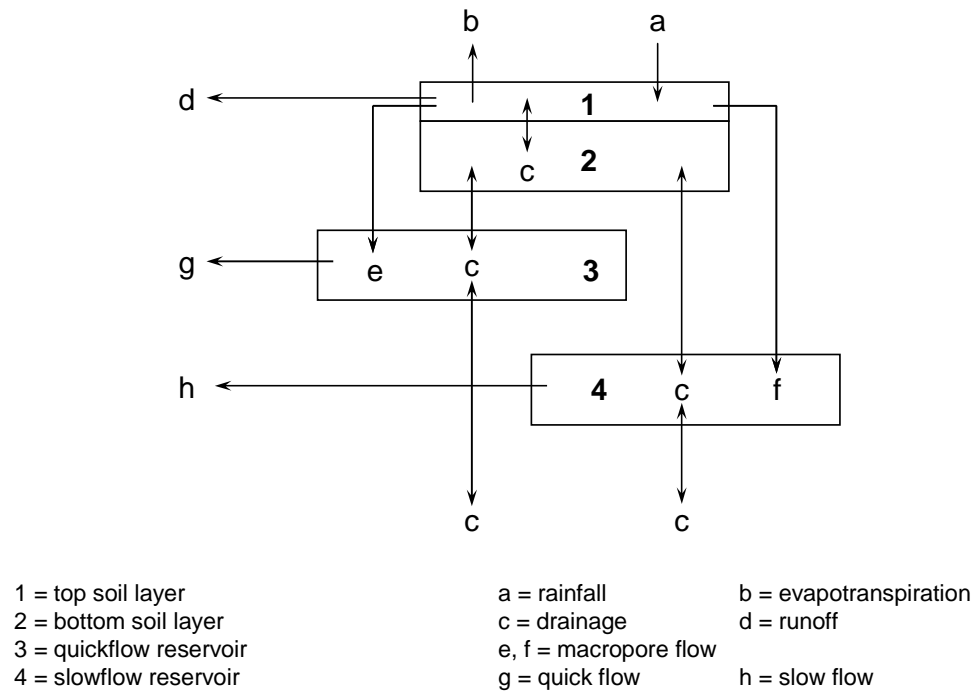




**Figure 2:** Surface catchments used in the ROTAN model. Lines show the stream flow connections. Catchments without lines (white) contribute groundwater to the lake but not stream flow.

In ROTAN there is a single land use layer comprising a number of functional units (FU) which is underlain by 1-3 aquifer layers (Figure 3). FUs are defined by intersecting GIS layers of surface catchment boundaries, vegetation cover, land use, soil drainage and rainfall. Maps for 1940, 1958, 1986, 1996, 2001 and 2003 are used in this study. Water balance calculations are performed on each FU and the results combined to estimate stream flows and drainage rates into any underlying aquifers. Each FU has a characteristic set of coefficients that quantify interception, infiltration, drainage, and evapotranspiration. FU coefficients do not vary over time but land use changes are simulated by allowing the spatial distribution of FUs to change.

Within each FU there are 4 sub-layers (Figure 3). The top 2 sub-layers encompass the root-zone in which are simulated interception, infiltration, evapotranspiration and drainage. Surface runoff is simulated by infiltration-excess and saturation-excess runoff during heavy rain, although neither process occurs very often in the free-draining pumice soils of the central volcanic plateau. The bottom 2 sub-layers are conceptual reservoirs that represent quick-flow (viz., shallow sub-surface flow to streams with a time scale of days) and slow-flow (viz., sub-surface flow to streams with a time scale of weeks-months).



**Figure 3:** Conceptual rainfall-runoff model that operates in each Functional Unit (top) and connections between Functional Units, Aquifers and Springs (bottom).

Each FU is assigned a nitrogen export rate ( $\text{kgN ha}^{-1} \text{ yr}^{-1}$ ) estimated using Overseer®. Differences in rainfall and drainage are assumed to have no effect on nitrogen export rate. For example the FU termed ‘Pasture1’ is assigned a total export rate of  $10 \text{ kgN ha}^{-1} \text{ yr}^{-1}$  and this export rate is applied to all ‘Pasture1’ polygons in the catchment, regardless of location, rainfall region or drainage region. Nitrogen can be exported from each of the 4 sub-layers. The rate of release of nitrogen, evapotranspiration (sub-layer 1 only), drainage and runoff determines the nitrogen concentration in water exported from each sub-layer. By sub-dividing the total nitrogen export between sub-layers, the model simulates different pathways to the lake and different delivery times. Thus nitrogen generated in sub-layer 3 reaches the stream and hence the lake soon after it is generated via quickflow following rainfall, whereas nitrogen generated in sub-layers that drain to groundwater reaches the lake years-decades after it is generated.

In the model a proportion of the surface, quick and slow flow can pass through wetlands and/or riparian zones where nitrogen removal occurs. Each surface catchment contains a stream which receives flow from the FUs within that catchment and may also receive springflow from one or more aquifers. Nitrogen removal can also occur in the stream channel. In this way ROTAN can simulate nutrient attenuation.

Drainage occurs from each sub-layer within a FU into any underlying aquifers. Up to 3 aquifers can underlie the surface layer containing the FUs but only 1 aquifer is used in this study. The boundaries of the aquifers need not coincide with boundaries of the surface catchments and this allows groundwater to flow into the lake from land outside the surface catchment. Horizontal groundwater flow is estimated using Darcy’s Law. Groundwater can either flow into an adjacent aquifer or it can emerge as springflow at the outlet of the overlying surface catchment. The proportion of springflow emerging from an aquifer is defined by the user. Figure 4 shows the aquifers used in this study and the connections between aquifers. Note that groundwater which emerges as springflow enters the lake as streamflow (e.g., in the Hamurana) but the connection to the lake is still shown in Figure 4. Direct groundwater flow to the lake can be simulated by setting the proportion of springflow that re-emerges in the catchment adjacent to the lake to be  $<1$ .

### **Water balance**

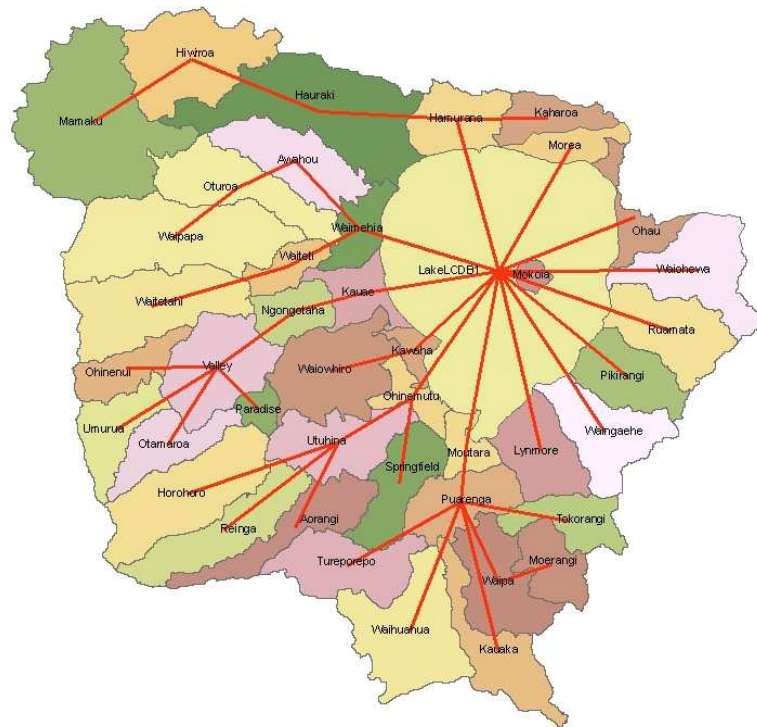
Rutherford et al. (2008) give details of the original hydrology calibration to achieve a water balance. Refinements were made during this study to incorporate the new Phase 7 GNS aquifer boundaries.

ROTAN aquifers are created by merging adjacent REC surface catchments. In this study the external aquifer boundaries (i.e., the outside boundary in Figure 4) were made to match the Phase 7 GNS boundaries as closely as was possible by merging REC surface catchments. Very slight differences exist between the ROTAN and GNS external boundaries (Figure 5) and both give a satisfactory (viz., within 5%) water balance at the lake outlet (see Tables 1 and 2). No changes were made to previously calibrated parameters for forest AET (1100 mm), pasture AET (800 mm), raingauge undercatch (5%) and interpolation bias (5%) (Rutherford et al. 2008). The ROTAN external aquifer boundaries encompass the entire surface catchment of the lake plus three additional catchments – Mamaku, Hiwiroa and Kaharoa (see Figure 2). Deep drainage from FUs in these additional catchments reaches the lake as groundwater, but streams in these additional catchments flow to the northwest or north out of the model domain. The surface area of these 3 additional catchments is 45 km<sup>2</sup> compared with 60 km<sup>2</sup> estimated previously (Rutherford et al. 2008). Given the uncertainty in rainfall and AET, there is no significant difference in these estimates.

**Table 1:** Summary of the water balance achieved using the ROTAN aquifer boundaries shown in Figure 4. Observed and predicted flows are the means for periods when observations are available from 1950-2008. The period of observations differs between streams.

Stream	Catchment area km <sup>2</sup>	Observed m <sup>3</sup> s <sup>-1</sup>	Yield <sup>1</sup> mm	Predicted m <sup>3</sup> s <sup>-1</sup>
Hamurana	2.8	2.7	34000	2.6
Awahou	16	1.6	3300	1.5
Waiteti	62	1.2	1400	1.3
Ngongotaha	73	1.8	1950	1.6
Waiowhiro	7.5	0.34	410	0.38
Utuhina	61	2.0	2020	2.0
Puarenga	73	1.8	2030	1.7
Waiohewa	14	0.33	370	0.41
Waingaehe	10	0.23	270	0.26
Ohau outlet	80.5 lake 497 lake + catchment	17.7	17.7	17.6

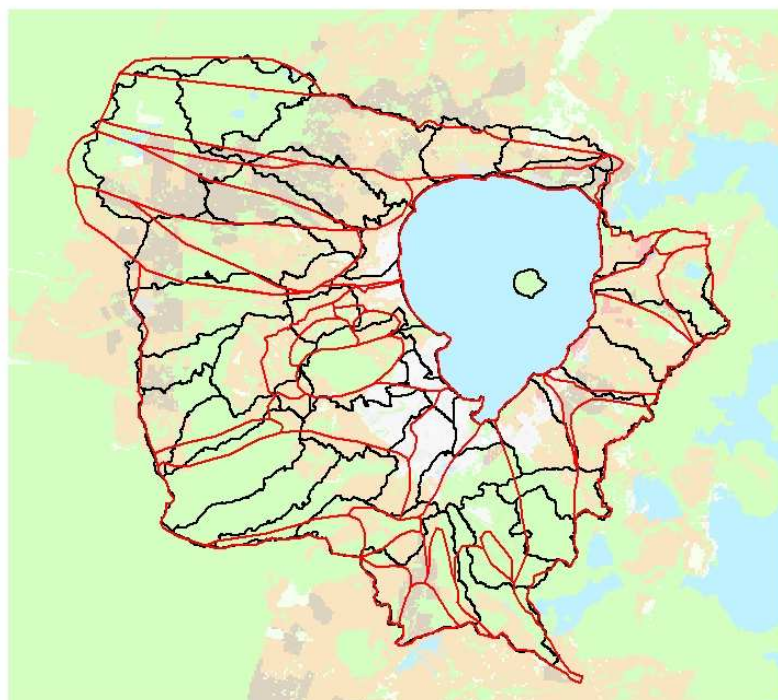
<sup>1</sup> from Rutherford et al. (2008)



**Figure 4:** Aquifers used in the ROTAN model. Lines show the groundwater flow connections. Where all the groundwater emerges as springflow (e.g., Hamurana) the connection to the lake is still shown although all the groundwater enters the lake as stream flow.

Internal aquifer boundaries in ROTAN are determined by merging adjacent REC surface catchments to give a satisfactory (*viz.*, within 10%) water balance in each major tributary. In this study aquifer boundaries were adjusted working anti-clockwise around the lake starting at the Hamurana. The northern boundary of the Hamurana-Hauraki-Hiwiroa-Mamaku aquifer system (Figure 4) was the external boundary established previously from the lake water balance. The Hauraki-Awahou boundary was defined such that the Awahou springs lay just within the Awahou aquifer. The boundary of the Mamaku aquifer was then defined to give a water balance at the Hamurana springs.

GNS aquifer boundaries are derived using the FEMWATER model. Boundaries are aligned parallel to predicted groundwater flow vectors and adjusted to achieve a flow balance (Dr Paul White, GNS, *pers. comm.*).



**Figure 5:** Comparison of Phase 7 aquifer boundaries estimated by GNS (red) and those used in ROTAN (black). Underlying land use is for 2001.

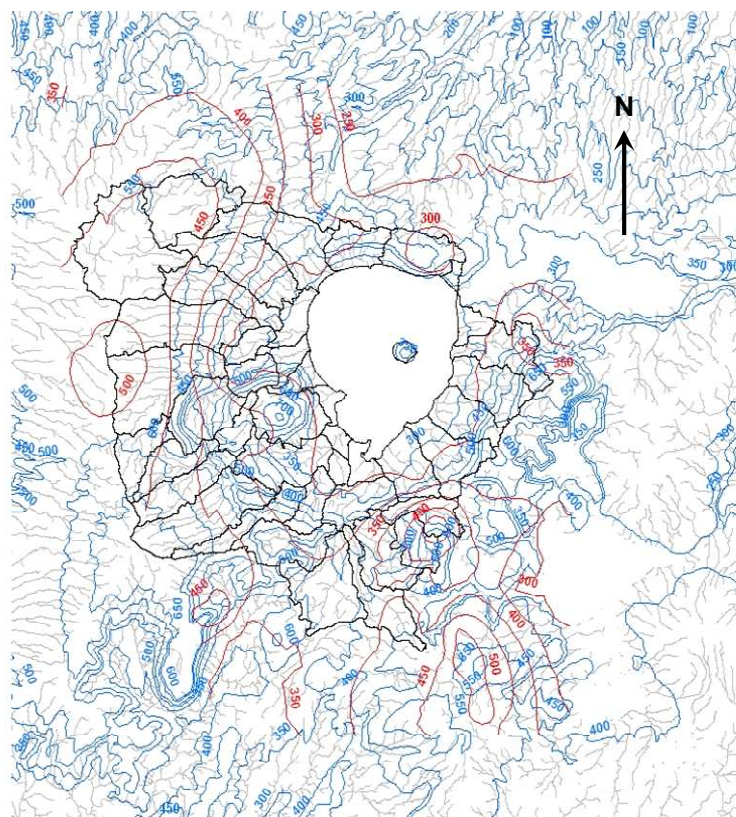
ROTAN and FEMWATER internal boundaries are very similar for the Kaharoa, Hamurana, Hauraki and Hiwiroa aquifers that feed the Hamurana springs. However, internal boundaries differ in the Mamaku aquifer (Figure 5). In ROTAN all the groundwater from Mamaku flows to the Hamurana springs via Hiwiroa and Hauraki (Figure 4). In FEMWATER about half of the groundwater from Mamaku flows to the Hamurana springs while the other half flows to the Awahou springs. ROTAN and FEMWATER use the same rainfall and AET and so it is likely that FEMWATER underestimates flow in the Hamurana springs.

In FEMWATER groundwater flows in a south east direction in the Mamaku aquifer (Paul White, GNS, *pers. comm.*). This is consistent with the peizometric head surface (Figure 6) which, in the Mamaku, slopes downwards towards the lake from north west to south east. In ROTAN groundwater flows in a north east direction from the southern part of the Mamaku aquifer into the Hiwiroa aquifer (Figure 4) and crosses the Phase 7 GNS aquifer boundary (Figure 5).

In ROTAN groundwater could be made to flow in a south east direction in the vicinity of the Mamaku aquifer in two ways. First, by including more of the Awahou aquifer, and less of the Mamaku aquifer, in the catchment of the Hamurana springs. This would, however, mean that the Awahou springs would no longer lie within the boundaries of the Awahou aquifer. Second, by using the multi-layer aquifer feature of ROTAN. In the current simulations ROTAN assumes a single aquifer layer which

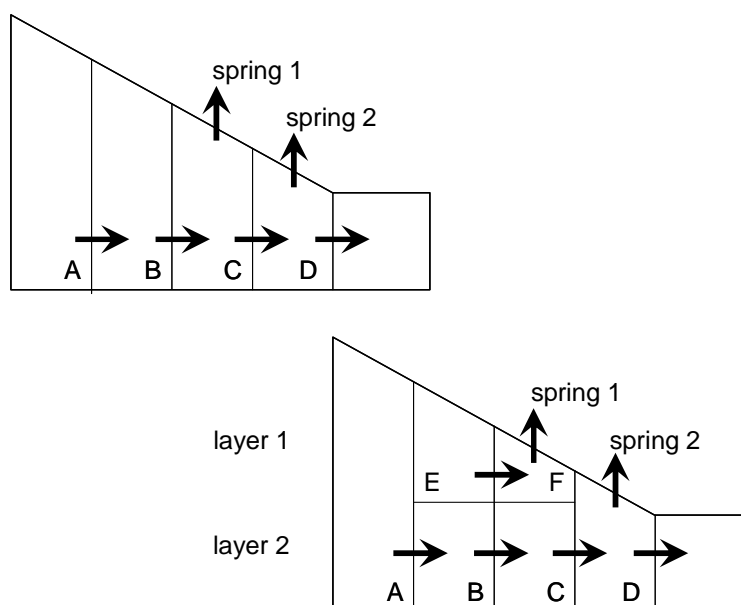
means groundwater can only flow between adjacent aquifers. Hence once the external aquifer boundary and the northern boundary of the Awahou aquifer were fixed, the only way to achieve a water balance in the Hamurana spring was to extend the Mamaku aquifer SW around the top of the Awahou aquifer. With multi-layer aquifers, groundwater can flow between non-adjacent aquifers (see Figure 7). The Awahou springs could be fed from a shallow aquifer, while a deeper aquifer could carry water north east under the Awahou aquifer to the Hamurana springs. This refinement could be added to ROTAN provided information is available to support a multi-layer calibration.

Alternatively, groundwater could flow towards the Hamurana springs from land to the north of the springs. This land is currently outside the external boundaries of both ROTAN and FEMWATER based on the peizometric head map. However, there are very few wells on the Kaharoa plateau to the north of Hamurana which leads to uncertainty in the location of the groundwater divide (viz., the external aquifer boundary). To maintain the water balance for the lake, it would be necessary to reduce the size of the Mamaku and Hiwiroa aquifers if the Hamurana and Hauraki aquifers were extended northwards.



**Figure 6:** Contours of peizometric head (red) (Source: GNS) and surface elevation (blue) (Source: REC). Units are m above mean sea level. Also shown (black) are the ROTAN aquifer boundaries. For an isotropic, homogeneous porous medium, groundwater flows at right angles to the peizometric head contours. There are few wells in some parts of the catchment (e.g., immediately north of the lake) which increases the uncertainty in inferred groundwater flows directions.

Having fixed the northern boundary of the Awahou aquifer (such that the Awahou springs lay just within the Awahou aquifer) it was necessary to include groundwater flow from the Oturoa and Waipapa aquifers in ROTAN in order to get a satisfactory water balance at the Awahou springs. This means that in ROTAN, groundwater flows to the NE from the Waipapa and Oturoa aquifers to the Awahou aquifer, and crosses the boundaries of the FEMWATER aquifers (Figure 5). This is at variance with FEMWATER simulations which show groundwater flows parallel to the Phase 7 GNS aquifer boundaries. Similarly, having included the Waipapa in the catchment of the Awahou springs, a flow balance in the Waiteti could only be achieved in ROTAN by assuming that groundwater flows NE from the Waitetahi into the Waiteti aquifer. Again this means that in ROTAN groundwater flows across the aquifer boundaries in FEMWATER.



**Figure 7:** Sketch of a 1-layer aquifer system (top) (as used in the current version of ROTAN) and a 2-layer aquifer system (bottom). In the 2-layer system nitrogen from E and F can reach spring 1 more quickly because it does not mix with B and C.

ROTAN was run with the Phase 7 GNS aquifer boundaries. A satisfactory water balance was achieved for the lake, but not in the Hamurana, Waiteti and Ngongotaha streams (Table 2). Flow was underestimated in the Hamurana and Awahou, and overestimated in the Waiteti and Ngongotaha. Since the water balance for the lake was satisfactory, it would be unreasonable to postulate groundwater flow into the lake bed in the Waiteti and Ngongotaha plus 'extra' inflows into the Hamurana and Awahou. It would seem reasonable, based on the water balances, to postulate groundwater flow in a NE direction from the Ngongotaha and Waiteti into the Awahou and Hamurana.



However, this implies groundwater flows at an oblique angle to the peizometric head slope and the flow direction predicted by FEMWATER.

The nitrogen predictions (described below) give a satisfactory match to observed stream TN concentrations and total lake nitrogen inputs. It seems unlikely that the differences in internal boundaries (described above) have a significant effect on nitrogen input predictions.

**Table 2:** Summary of the water balance achieved using the GNS Phase 7 aquifer boundaries shown in Figure 5 (red). Observed and predicted flows are the means for periods when observations are available from 1950-2008. The period of observations differs between streams. In streams shaded grey, observed and predicted flows differ by more than  $0.3 \text{ m}^3 \text{ s}^{-1}$  (c. 20%) which exceeds the likely uncertainty in observed flow.

Stream	Catchment area $\text{km}^2$	Observed $\text{m}^3 \text{ s}^{-1}$	Predicted $\text{m}^3 \text{ s}^{-1}$
Hamurana	2.8	2.8	2.3
Awahou	16	1.6	1.4
Waiteti	62	1.2	1.5
Ngongotaha	73	1.8	2.2
Waiowhiro	7.5	0.34	0.26
Utuhina	61	2.0	2.2
Puarenga	73	1.8	1.6
Waingaehe	10	0.23	0.27
Waiohewa	14	0.33	0.46
Ohau outlet	497 <sup>1</sup>	17.8	17.8

<sup>1</sup> including lake  $80.5 \text{ km}^2$

ROTAN achieved a satisfactory water balance in the Ngongotaha, Waiowhiro, Utuhina and Puarenga streams. In each of these catchments groundwater flows from outside the surface catchment. Thus, the Waiteti aquifer includes parts of the Waitetahi and Ohinenui surface catchments whose streams flow into the Ngongotaha. The Waiowhiro aquifer includes part of the Paradise and Mangakakahi surface catchments whose streams flow into the Ngongotaha and Utuhina respectively. The Utuhina aquifer includes parts of the Horohoro surface catchment whose streams flow into the Ngongotaha. The Puarenga aquifer includes part of the Springfield surface catchment whose streams flow into the Utuhina. The Lynmore receives groundwater from the Tokorangi catchments whose streams flow into the Puarenga. In the remaining catchments, aquifer and surface catchment boundaries coincide.

### Land cover/use maps

GIS maps for 1940, 1958, 1986, 1996, 1999, 2001 and 2003 were available for this study.

The 1940 land cover map was created from black and white aerial photographs – scanning and classification was done as part of this project by a contractor to EBoP. The 1958 map originated from Landcare, Palmerston North. It reports both land cover and land use, but only at a coarse spatial resolution. The 1986 and 1999 land cover maps are LANDSAT and ECOSAT images respectively. The 1999 ECOSAT image was not used because it focuses on forest types rather than pasture and provides little additional information to LCDB1 (Land Cover Data Base). The 1996 and 2001 land cover maps are LCDB1 and LCDB2 respectively. The 2003 map was supplied by EBoP and is based on LCDB2 (land cover) updated with 2003 land use data.

The 1958 and 2003 maps give land use as well as land cover, while the other maps give only land cover. The number of polygons in the GIS maps varied from a few hundred (1958) to a several thousand (1996). The 1996 (LCDB1) and 2001 (LCDB2) maps cover the entire study region while maps for other years are based on local government (not catchment) boundaries, and exclude some land outside the surface catchment (e.g., Hiwiroa, Mamaku and Kaharoa catchments in Figure 2). Topographic maps for the years 1952, 1964 and 1980 were used to help extend catchment boundaries but we relied mostly on LCDB1 and LCDB2.

In order to check and modify the available maps, they needed to be overlain and compared. However, the polygons in each map were derived independently and did not coincide. When the 6 maps were intersected an impossibly large number of polygons was created (~100,000), many of which were very small. To overcome this problem each map was converted to a 100 x 100 m raster with the same origin, and the predominant land cover/use was assigned to each grid cell. There were ~17,000 cells in each raster. Rasters were then converted back to shape files whose polygons were the same in each map. These maps were then intersected and land cover or land use in each of the ~17,000 polygons compared over time.

Data were exported to Excel and ‘rules’ written in VBA to identify and remove inconsistencies in the data, and to estimate land use from land cover. These rules are detailed in Appendix 1.

This method has two main sources of uncertainty:

1. 1958 land use classification was very coarse. For example, some polygons classified ‘Dairy’ in 1958 were classified ‘IndigenousForest’ or ‘Scrub’ in 1986 and 1996. Although the ‘rules’ in Appendix 1 sought to eliminate inconsistencies such as this, there is some uncertainty about their effectiveness.
2. Where land use intensification occurred between 1958 and 2003 it was not possible to estimate whether intensification occurred in 1986, 1996 or 2001 because those maps

only show land cover and not land use. Again the 'rules' in Appendix 1 sought to estimate when land use changes occurred based on agricultural statistics for the Rotorua region (discussed in Section 3) but there is some uncertainty about their effectiveness.

The Rotorua sewage treatment plant was commissioned in 1973. In the 1940 and 1958 maps land classified 'UrbanBuilt' was assigned the class 'SepticTanks'. In the 1986 and later maps 'UrbanBuilt' land within Rotorua city, the eastern suburbs and Ngongotaha was assigned the class 'UrbanSewered', while elsewhere it was assigned the class 'SepticTanks'. From 1973-1991 a small area of land near Sulphur Bay was assigned the class 'SewageTreatmentPlant' and used to simulate the nutrient load from treated sewage. In 1991 this land was re-designated 'UrbanOpenSpace' and the spray disposal areas in Whakarewarewa Forest was assigned the class 'RLTS' (Rotorua Land Treatment System). Small areas of land at Tikitere and Whakarewarewa were assigned the class 'Tikitere' and 'Whaka' and used to simulate geothermal nitrogen inputs.

### 3. Agricultural statistics

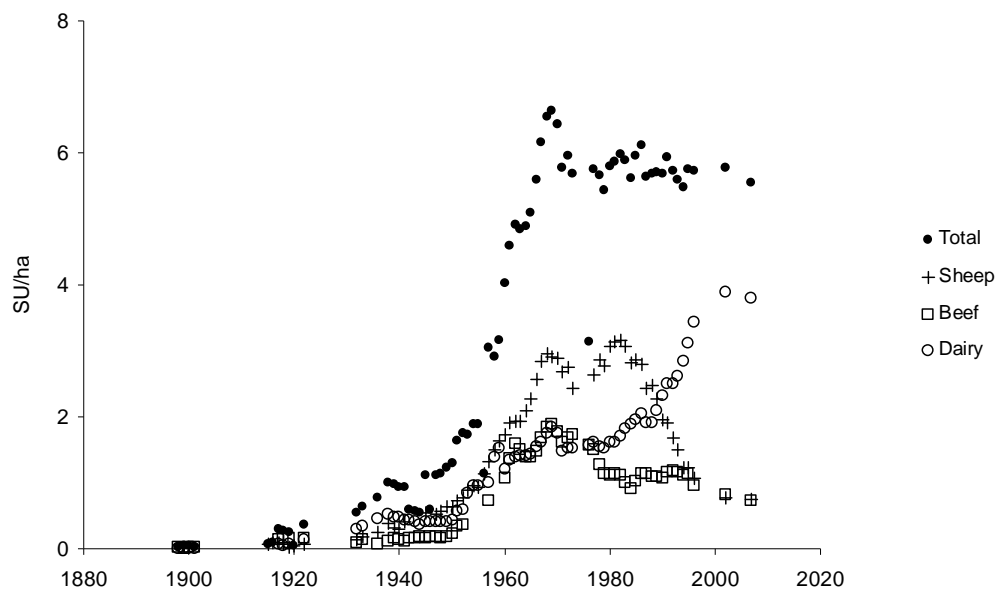
Palliser and Rutherford (2009) have collated annual agricultural statistics from 1898-2007 which are used in Overseer® to estimate nitrogen leaching rates. Data were collated from New Zealand Year Books, Agricultural Production Reports, the Statistics New Zealand website (INFOS), and the Ministry of Agriculture and Forestry. Over time there have been significant changes to the methods of collecting agricultural statistics, the boundaries of the reporting areas, the types of farming enterprise included, the way in which land use and land cover is reported, and the way in which livestock numbers are reported. These changes affect the accuracy with which stocking rates for each animal type can be estimated in the Rotorua catchment.

**Table 3:** Stock unit conversions used in this study. Source: [www.ew.govt.nz/Environmental-information/Environmental-indicators/Land-and-soil/Land/riv9-technical-information](http://www.ew.govt.nz/Environmental-information/Environmental-indicators/Land-and-soil/Land/riv9-technical-information).

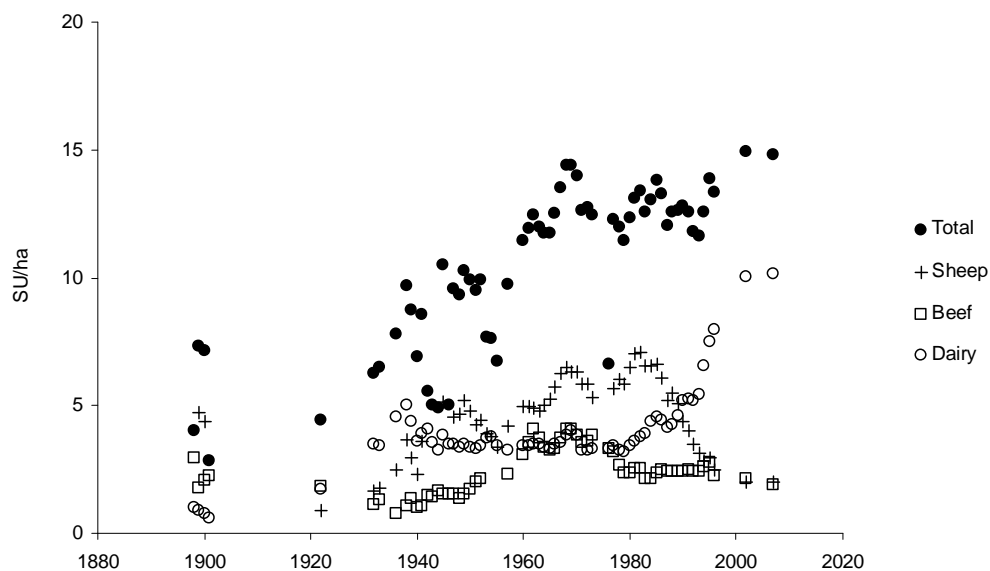
Animal type	SU
Sheep	0.93
Beef	4.8
Dairy	6.3
Deer	5

Figure 8 shows total stock units (SU) divided by the total area of Rotorua District. Animal numbers have been converted to stock units using the conversion factors in Table 3. In the Rotorua District stock units increased slowly from 1900-1950. Immediately after WWII stock units increased, coinciding with an increased work force, aerial topdressing and methods to overcome 'bush sickness'. Stock numbers peaked during the 1970s, followed by a significant reduction. Total stock units have remained almost constant since the 1980s but dairy units have increased and sheep units have decreased.

Figure 9 shows total SU divided by the total area of pasture in the district. Total stocking rate is highly variable from 1900-1960, probably because of variations in the methods of collecting and reporting agricultural statistics. Total stocking rate increased significantly after WWII and peaked in the 1970s. Thereafter there was some reduction in total stocking rate which coincided with the removal of farm subsidies. Total stocking rate has increased again in recent years. The points labelled 'Total' provide a reliable estimate of the average stocking rate for all animals combined. The points for each animal type, however, are not reliable estimates of the true stocking rate for that animal type. This is because, in the case of sheep, the points are the total number of sheep divided by the total area of pasture and this is grazed by sheep, beef and cows.

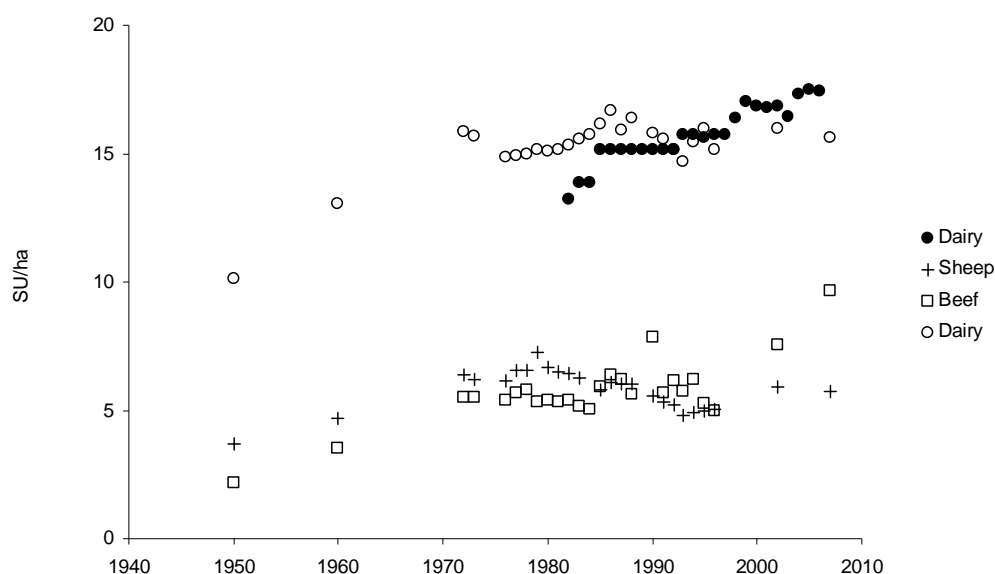


**Figure 8:** Stock density in Rotorua District 1898-2007. Figures are animal numbers divided by total land area. Animal numbers are converted to SU using the conversion factors in Table 3.



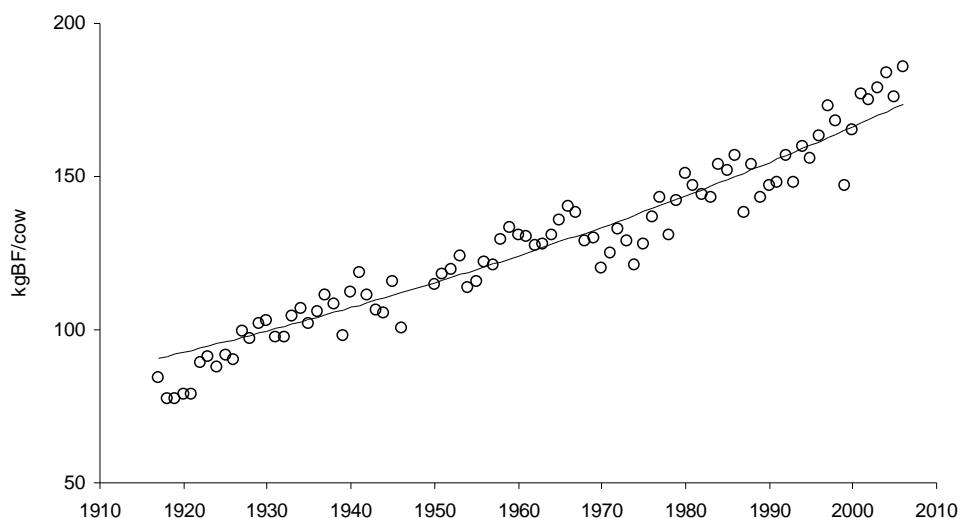
**Figure 9:** Stock density in Rotorua District 1898-2007. Figures are animal numbers, converted to SU, divided by area of pasture.

Figure 10 shows national stocking rate statistics. Some, but not all, Agricultural Production Reports list pasture area and stock numbers for particular farm types. Data are presented for farms where cows, beef or sheep made up >85% of total stock units and hence are close to ‘true’ stocking rates. Figure 10 contains dairy stocking rates from two independent datasets – results are broadly consistent which increases our confidence in the methods used. There are no equivalent data for the Rotorua District or Lake Rotorua catchment.



**Figure 10:** National stocking rates 1950-2007. Figures are animal numbers, converted to SU, divided by area of pasture for farms that are predominantly dairy, beef or sheep. For Dairy open circles are from Agricultural Production Reports while closed circles are from LIC (2007). Animal numbers are converted to SU using the conversion factors in Table 3.

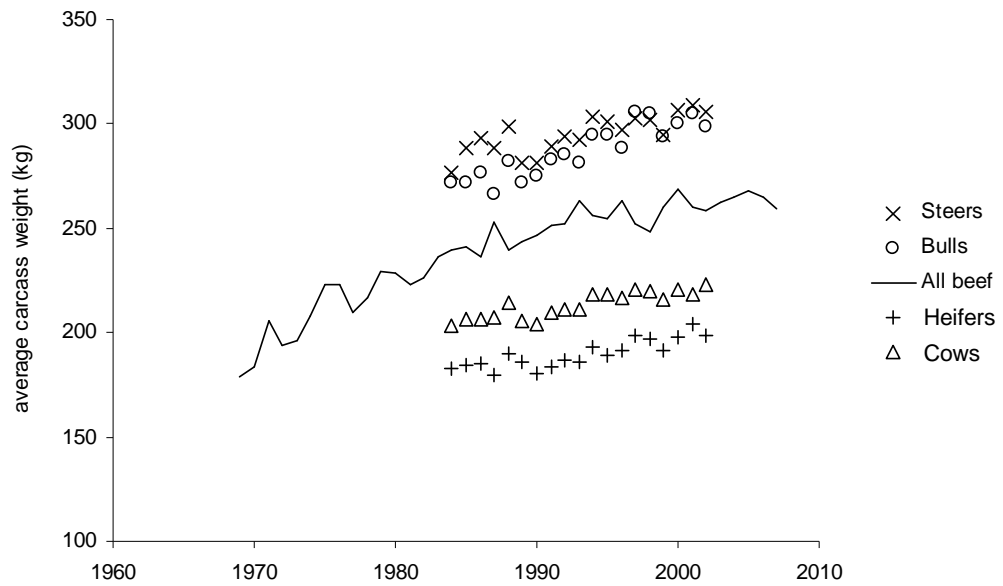
Figure 11 shows that there has been a significant increase in butterfat production per cow over the period 1916-2006. Note that both stocking rate (cows ha<sup>-1</sup>) and butterfat production per cow (kgBF cow<sup>-1</sup>) have increased over time, and as a result, production per unit area (kgBF ha<sup>-1</sup>) has increased dramatically. The nitrogen leaching calculations described in the next section account for the increasing trend in milk production.



**Figure 11:** Trends in butterfat (BF) production 1916-2006. Figures are butterfat production divided by numbers of cows in milk. Sources: LIC (2007) and New Zealand Yearbooks 1920, 1940, 1950, 1957 and 1965.

Data on average carcass weight for cattle (Figure 12) show a significant increasing trend from 1970-2002. Woodford and Nicol (2005) point out that carcass weight is only a surrogate for live animal weight. Nevertheless, the strong inference is that the average weight of animals on farms increased during this period. This is likely to be the result of farmers choosing heavier breeds, selection for larger animals, and improved feed (Woodford and Nicol 2005). There are no reliable data for average cattle weight prior to 1970. Data for sheep in Figure 13 also show an increase in average carcass weight from 1980-2006. However, carcass weights for sheep from 1920-1960 were similar to current weights, with a marked decline from 1960-1980. The minimum average carcass weight occurred around 1970 and this corresponds with high stocking rates (see Figure 8).

The nitrogen leaching calculations described in the next section do not account for changes in the average weight of sheep or beef cattle during the study period but they do account for changes in stocking rate.



**Figure 12:** Trends in carcass weight for cattle 1970-2006. Symbols are from Woodford and Nicol (2005). Line is from Meat and Wool New Zealand Economic Service.



**Figure 13:** Trends in carcass weight for sheep 1923-2006. Symbols are data from Woodford and Nicol (2005) while the lines are data supplied by Meat and Wool New Zealand Economic Service.

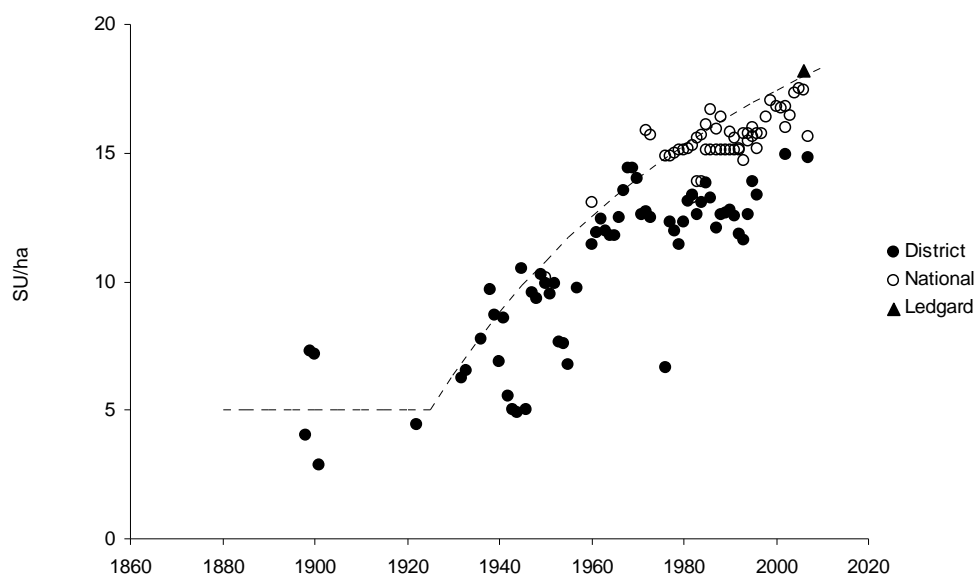


## 4. Nitrogen inputs

### Runoff from farmland

Nitrogen export rates from farmland are estimated for each polygon using Overseer®. Nitrate leaching rate depends on soil type, hydrology, animal type and stocking rate, and is sensitive to the amount of nitrogen fertiliser applied. Rotorua soils were classified as either ‘very well drained’ or ‘well drained’ based on information in the National Soils Database and whether or not streams were perennial or ephemeral.

For dairy farms, Overseer® requires stocking rate (cows ha<sup>-1</sup>), breed (Jersey, Friesian etc.) and milk solids production (kgMS ha<sup>-1</sup> yr<sup>-1</sup>). Pastoral farming in Rotorua district has been a mix of dairy, sheep and sheep/beef since the early 1900s. From 1980-2006 total stocking rates (dairy + beef + sheep) for the Rotorua district (‘District’ in Figure 14) plot slightly below national stocking rates for dairy farms (‘National’ in Figure 14). This is consistent with a mix of dairy, sheep and beef farming in the district, and with dairy farms having higher stocking rates than sheep and beef farms. Smeeton and Ledgard (2007) surveyed several dairy farms in the Rotorua catchment and found an average stocking rate equivalent to 18.2 SU ha<sup>-1</sup> (Dr Stewart Ledgard, AgResearch, *pers. comm.*).



**Figure 14:** Trends in stocking rate for dairy cows. ‘District’ data are stocking rates for all animals (dairy, sheep and beef) on all farms in Rotorua district. ‘National’ are national stocking rates for cows on dairy farms. ‘Ledgard’ are stocking rates from Smeeton & Ledgard (2007). The line is used to quantify stocking rates on dairy farms in the Rotorua catchment.

The line in Figure 14 is an upper bound for the ‘District’ and ‘National’ points passing through the ‘Ledgard’ point. There is high uncertainty in dairy stocking rates from 1900-1960 but lower uncertainty thereafter. Stocking rates in cows ha<sup>-1</sup> – required by Overseer® – were estimated from the trend line in Figure 14 by dividing by 6.3 SU cow<sup>-1</sup>. When making the Overseer® calculations for dairy farms we also assumed (see Table 4) that: (1) the predominant dairy breed changed, (2) application of urea fertiliser started in the 1980s and (3) milk solids production increased over time.

Nitrogen export rates predicted using Overseer® increased from 9-57 kgN ha<sup>-1</sup> yr<sup>-1</sup> for dairy farms north of Rotorua City in the period 1900-2005 (Table 4 and Figure 18). The increase around 1990 is associated with an increase in the use of urea fertiliser. Smeeton and Ledgard (2007) recently reported that nitrogen leaching rates from dairy farms at Rotorua for the ‘base year’ (2005-06) averaged 58 kgN ha<sup>-1</sup> yr<sup>-1</sup>. This is slightly higher than our estimated value of 55 kgN ha<sup>-1</sup> yr<sup>-1</sup> for 2005.

**Table 4:** Nitrogen export rate for dairy farms estimated using Overseer®. J = Jersey, F = Friesian, CB1 = cross bred (predominantly Jersey-Friesian), CB2 = cross bred (predominantly Holstein-Friesian). North and South are relative to Rotorua City.

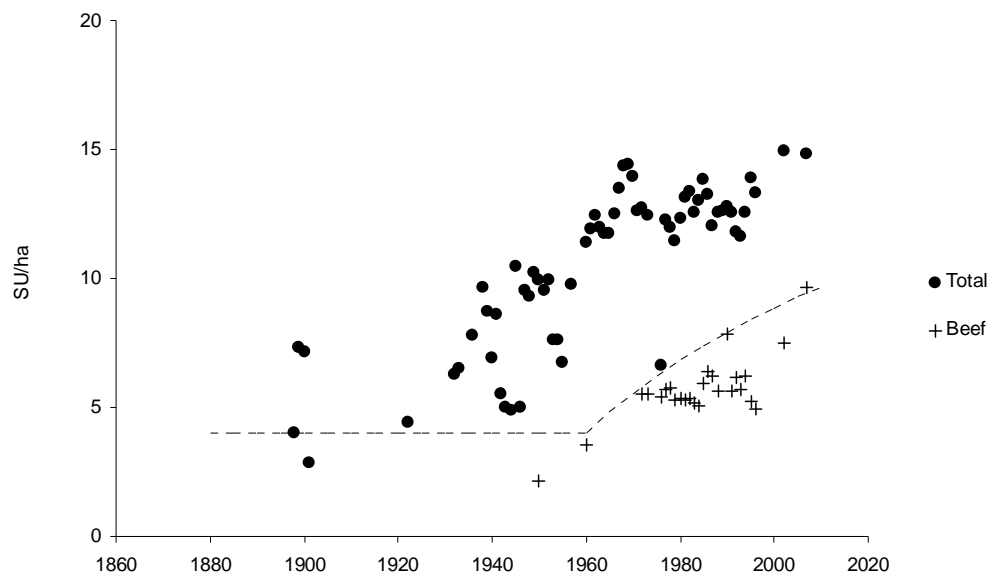
Year	Stocking cows/ha	Breed	Stocking SU/ha	Production kgMF/cow	Production kgMS/cow	Fertiliser kgN/ha/yr	Leaching North kgN/ha/yr	Leaching South kgN/ha/yr
1880	0.8	J	5.0	69	121	0	9	7
1885	0.8	J	5.0	72	125	0	9	7
1890	0.8	J	5.0	74	130	0	9	7
1895	0.8	J	5.0	77	135	0	9	7
1900	0.8	J	5.0	80	140	0	9	7
1905	0.8	J	5.0	83	145	0	9	7
1910	0.8	J	5.0	86	151	0	9	7
1915	0.8	J	5.0	89	156	0	9	7
1920	0.8	J	5.0	93	162	0	9	7
1925	0.8	J	5.0	96	168	0	10	8
1930	1.0	J	6.4	100	174	0	11	9
1935	1.2	J	7.6	103	181	0	13	10
1940	1.4	J	8.8	107	188	0	14	11
1945	1.6	J	9.8	111	195	0	15	12
1950	1.7	J	10.8	115	202	0	17	14
1955	1.9	J	11.7	120	209	0	18	14
1960	2.0	J	12.5	124	217	0	20	16
1965	2.1	CB1	13.3	129	225	0	23	18
1970	2.2	CB1	14.0	134	234	0	24	19
1975	2.3	CB1	14.7	138	242	50	29	23
1980	2.4	CB1	15.3	144	251	100	34	27
1985	2.5	CB1	15.9	149	261	100	35	28
1990	2.6	CB2	16.4	155	270	200	51	41
1995	2.7	CB2	16.9	160	281	200	53	42
2000	2.8	CB2	17.4	166	291	200	54	43
2005	2.8	CB2	17.9	172	302	200	55	44
2010	2.9	CB2	18.3	179	313	200	57	45

**Table 5:** Nitrogen export rate for sheep, beef and sheep/beef farms estimated using Overseer®. North and South are relative to Rotorua City.

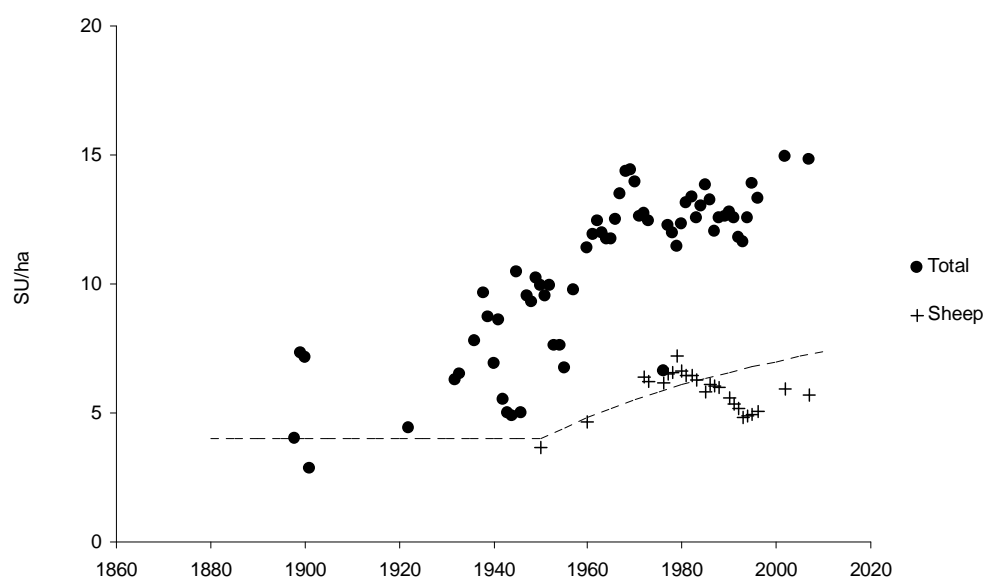
Year	Sheep		Beef		Sheep/Beef			
	Stocking SU/ha	Leaching kgN/ha/yr	Stocking SU/ha	Leaching kgN/ha/yr	North		South	
					Stocking SU/ha	Leaching kgN/ha/yr	Stocking SU/ha	Leaching kgN/ha/yr
1880	4.0	10	4.0	15	4.0	12	4.0	12
1885	4.0	10	4.0	15	4.0	12	4.0	12
1890	4.0	10	4.0	15	4.0	12	4.0	12
1895	4.0	10	4.0	15	4.0	12	4.0	12
1900	4.0	10	4.0	15	4.0	12	4.0	12
1905	4.0	10	4.0	15	4.0	12	4.0	12
1910	4.0	10	4.0	15	4.0	12	4.0	12
1915	4.0	10	4.0	15	4.0	12	4.0	12
1920	4.0	10	4.0	15	4.0	12	4.0	12
1925	4.0	10	4.0	15	4.0	12	4.0	12
1930	4.0	10	4.0	15	4.0	12	4.0	12
1935	4.0	10	4.0	15	4.0	12	4.0	12
1940	4.0	10	4.0	15	4.0	12	4.0	12
1945	4.0	10	4.0	15	5.1	15	4.7	13
1950	4.0	10	4.0	15	6.0	18	5.4	16
1955	4.7	11	4.0	15	6.9	20	6.0	18
1960	5.3	11	4.0	15	7.8	22	6.5	19
1965	5.8	13	4.8	18	8.5	24	7.0	20
1970	6.3	14	5.5	20	9.2	26	7.5	21
1975	6.8	15	6.2	22	9.8	28	7.9	22
1980	7.2	16	6.8	24	10.4	29	8.3	23
1985	7.6	17	7.4	26	11.0	31	8.7	24
1990	8.0	18	7.9	28	11.5	32	9.0	25
1995	8.3	18	8.4	29	12.0	33	9.3	26
2000	8.7	19	8.9	31	12.4	35	9.6	27
2005	9.0	20	9.3	32	12.9	36	9.9	28
2010	9.3	20	9.7	34	13.3	37	10.2	29

For beef, sheep and mixed sheep/beef farms Overseer® requires, as a minimum, stocking rate (SU ha<sup>-1</sup>) by animal type. There are currently no ‘sheep only’ or ‘beef only’ farms in Rotorua (Alastair MacCormack, EBoP, *pers. comm.*) although the GIS map for 2003 (based on LCDB2) does classify some land parcels as ‘sheep’ or ‘beef’. National statistics indicate that stocking rates on beef-only farms have increased steadily since 1950 (Figure 15).

**Figure 15:** Trends in stocking rate for beef cattle. ‘Total’ data are stocking rates of all animals on all farms Rotorua district. ‘Beef’ are national stocking rates for beef cattle on beef only farms. The line is used to quantify stocking rates on beef only farms in the Rotorua catchment.

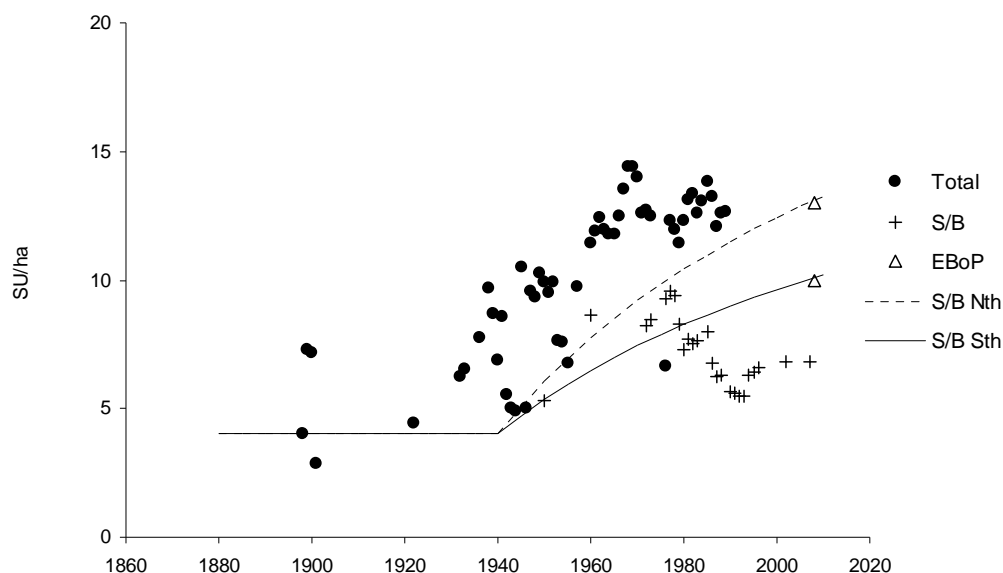


National stocking rates on sheep farms increased from 1940 to 1980 and then declined (Figure 16). This is possibly the result of: (1) North Island sheep farms having higher stocking rates than South Island (high country) sheep farms, and (2) many North Island sheep farms converting to sheep/beef. The coefficients of the trends lines in Figures 15 and 16 are trained to national statistics but the shape is constrained to follow the monotonic increase in total stocking rate for Rotorua.



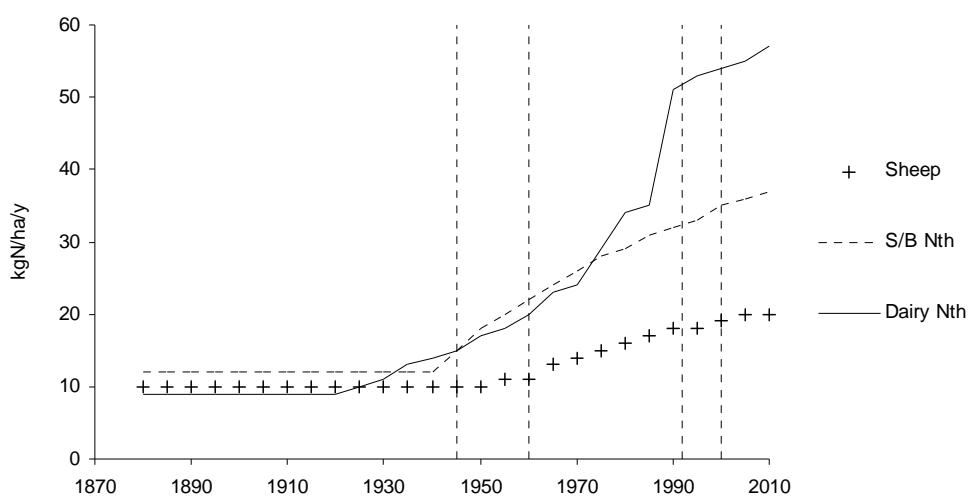
**Figure 16:** Trends in stocking rate for sheep farms. ‘Total’ data are stocking rates of all animals on all farms Rotorua district. ‘Sheep’ are national stocking rates for sheep on sheep only farms. The line is used to quantify stocking rates on sheep only farms in the Rotorua catchment.

National stocking rates on sheep/beef farms also increased from 1940 to 1980 and then declined (Figure 17). Data supplied by a consultant to EBoP (Alastair MacCormack, EBoP, *pers. comm.*) indicates current stocking rates on sheep/beef farms of 12-13 SU ha<sup>-1</sup> north of Rotorua City and 10.5-12 SU ha<sup>-1</sup> south of Rotorua City. The difference reflects farms south of the city being at a higher elevation and colder. These stocking rates do not match national trends (see points labelled ‘EBoP’ in Figure 17). While the reasons for this are not clear, it seems likely that national statistics are strongly influenced by South Island data which may not be representative of Rotorua. The trend line for sheep/beef is trained to national data for 1940-1980 and then to recent EBoP data assuming stocking rates in 2008 of 13 and 10 SU ha<sup>-1</sup> north and south of the city respectively. Making this assumption, nitrogen leaching rates estimated using Overseer® are on average 20% lower south of the city.



**Figure 17:** Trends in stocking rate for sheep/beef farms. ‘Total’ are stocking rates of all animals on all farms Rotorua district. ‘S/B’ are national stocking rates on sheep/beef farms. ‘EBoP’ are stocking rates on sheep/beef farms determined by EBoP (Alastair MacCormack., EBoP, *pers. comm.*). Nth and Sth refer to an East-West line drawn through Rotorua City. The dashed lines are used to quantify stocking rates on sheep/beef farms in the Rotorua catchment.

Nitrogen export rates predicted using Overseer® increased from 15-34 kgN ha<sup>-1</sup> yr<sup>-1</sup> for beef, from 10-20 kgN ha<sup>-1</sup> yr<sup>-1</sup> for sheep and from 12-37 kgN ha<sup>-1</sup> yr<sup>-1</sup> for sheep/beef farms north of Rotorua City (Table 5, Figure 18).



**Figure 18:** Trends in nitrogen export rates for sheep, sheep/beef and dairy farms in Rotorua District estimated using the Overseer® model. Stocking rates, fertiliser use, animal breed and other information used are summarised in Tables 4-5. The vertical lines indicate where a step change in land use is assumed in the model.

**Table 6:** Nitrogen yields ( $\text{kgN ha}^{-1} \text{yr}^{-1}$ ) assigned to various land use classes 1940-2003. Not all land use classes occur in all years. STP is Sewage Treatment Plant.

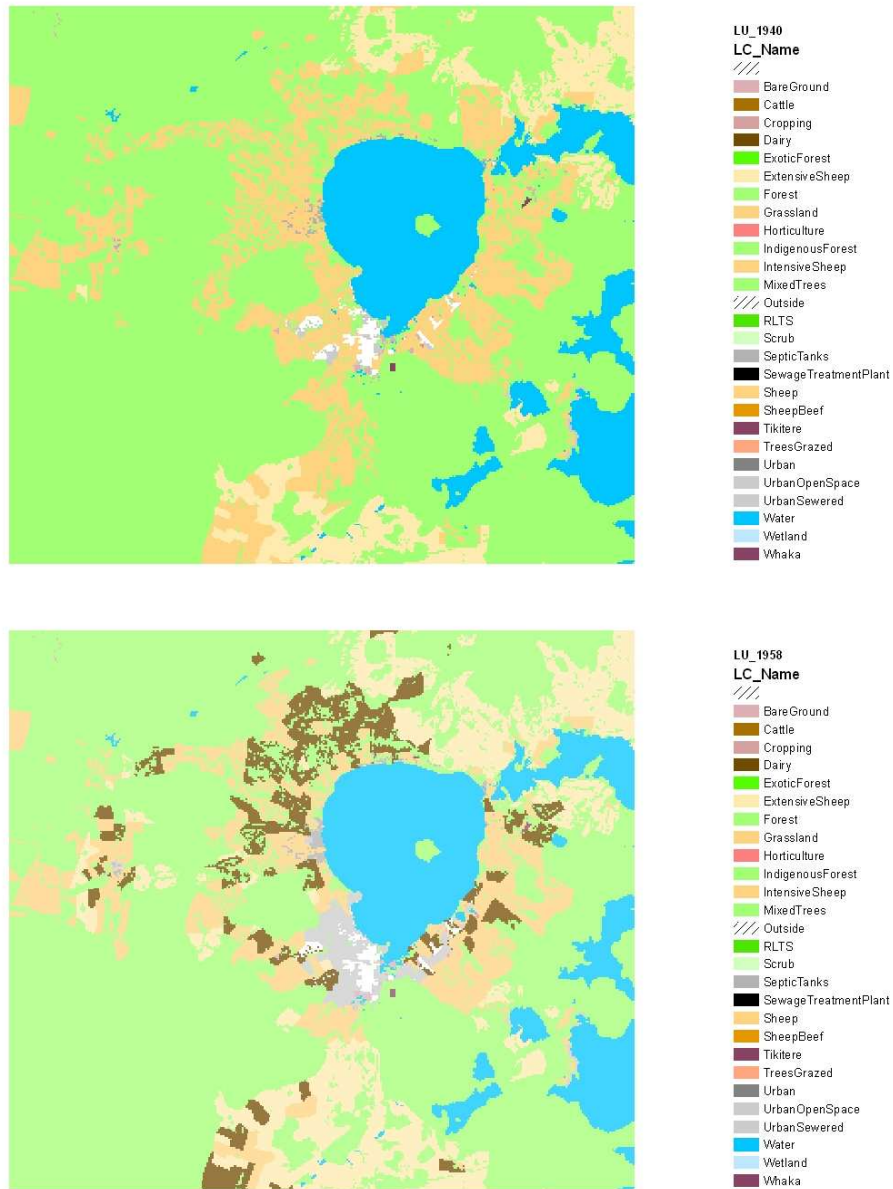
LC	1940	1958	1986	1996	2001	2003
BareGround	5	5	5	5	5	5
Cropping	25	25	25	25	25	25
Forest	4	4	4	4	4	4
Horticulture	25	25	25	25	25	25
IndigenousForest	4	4	4	4	4	4
Cattle			25	30	30	30
Dairy North		20	35	55	55	55
Dairy South		15	25	30	35	35
SheepBeef North			30	35	35	35
SheepBeef South			25	25	30	30
Sheep	10		15	20	20	20
ExtensiveSheep	10	10	10	15		
IntensiveSheep	10	15	15			
TreesGrazed					20	20
Urban	50	50	50	10	10	10
UrbanOpenSpace	10	10	10	10	10	10
RuralSepticTanks	50	50	50	50	50	50
RLTS	4	4	4	100	100	60
STP	10	10	STP	10	10	10

The distributions of land use ranked according to nitrogen export rate are shown in Table 6 and Figure 19. They show the expansion of the Rotorua City urban area and the intensification of land use – notably in the north-west and south-east of the catchment.

ROTAN allows the input of up to 5 FU maps describing the spatial distribution of land use. It also allows two alternatives: (1) a step change in land use at a specified date, or (2) linear or user defined interpolation between dates. In this study a step change in land use was assumed. FU maps were derived from land use data in 1940, 1958, 1986, 1996 and 2001. Guided by trends in stocking rate (Figure 9) these maps were assumed to describe land use as shown in Table 7. Table 8 summarises the areas of each land use class.

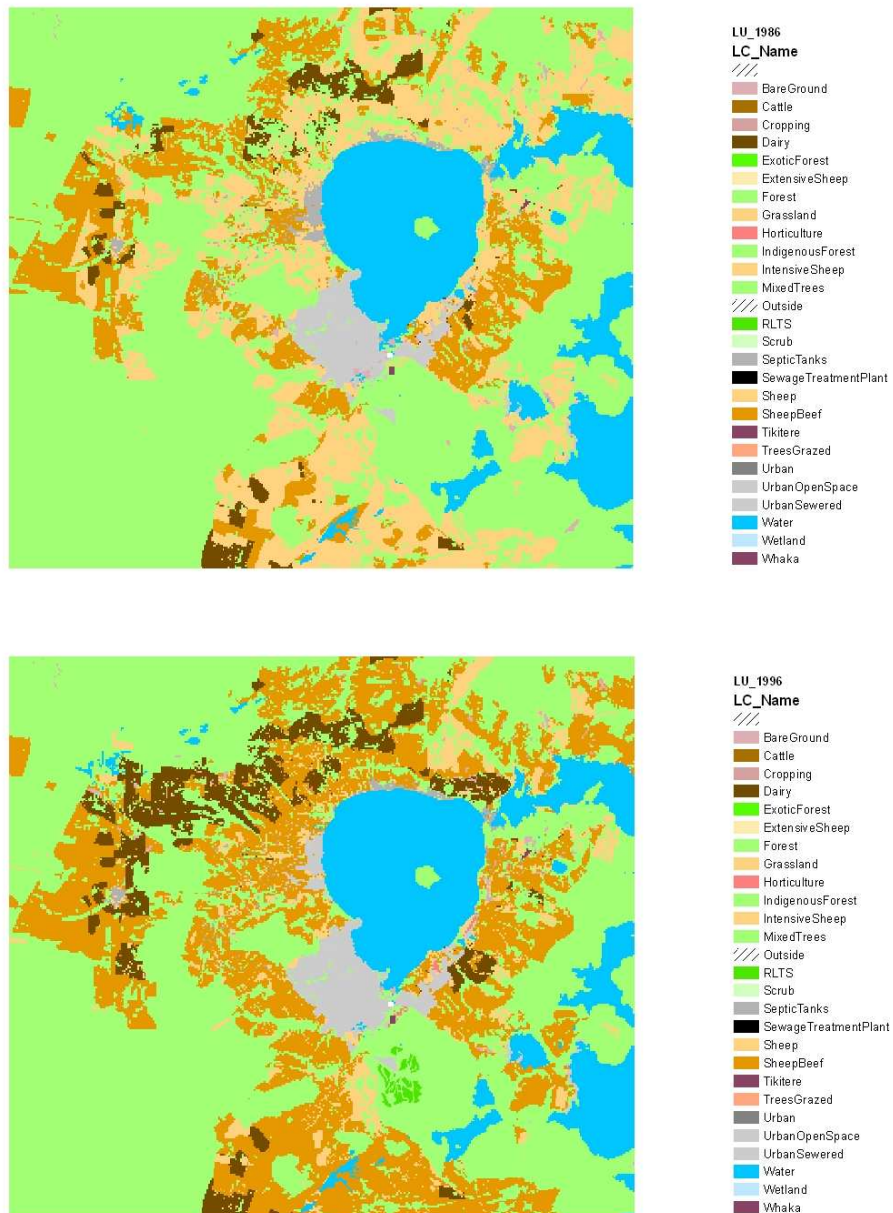
**Table 7:** LU maps used in the ROTAN simulations and the time periods they cover.

<b>LU map</b>	<b>Start</b>	<b>End</b>
1940	1900	1945
1958	1945	1960
1986	1960	1992
1996	1992	2002
2001	2002	2008

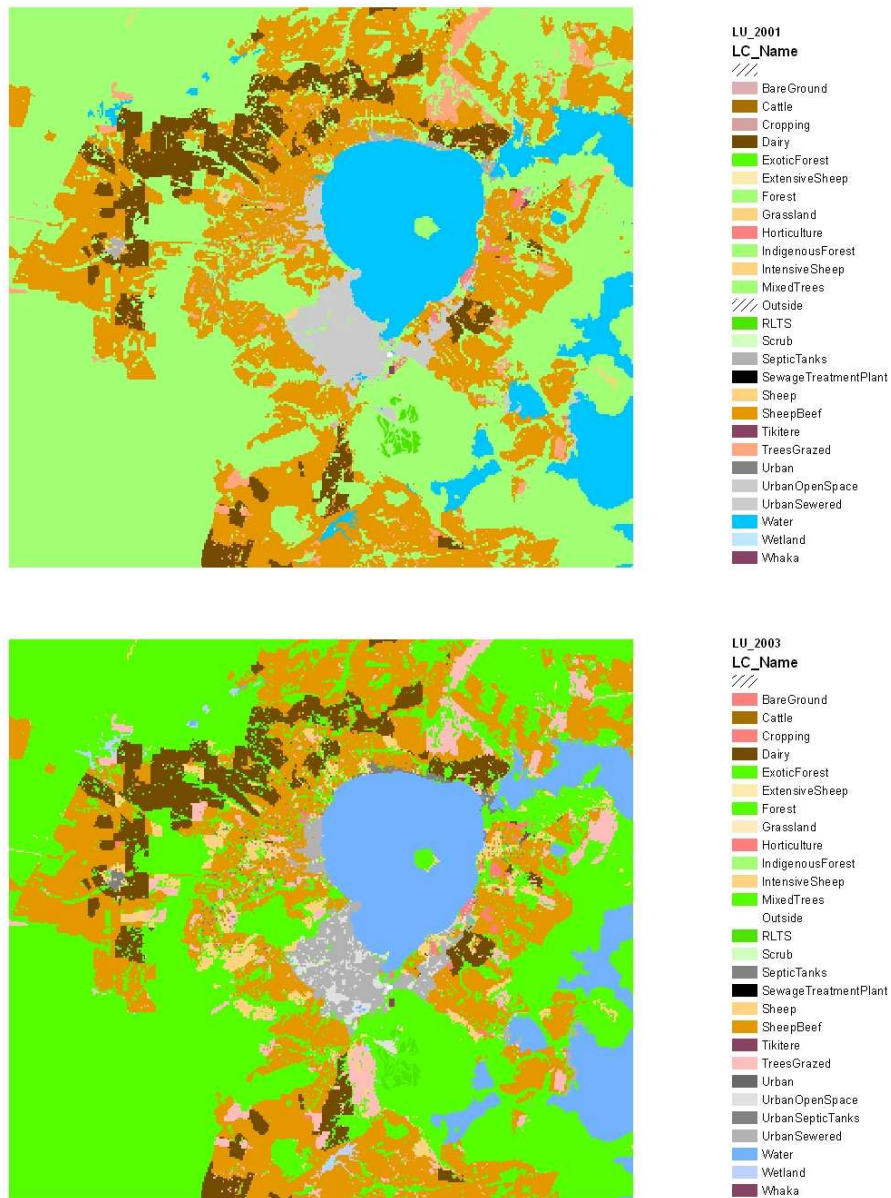


**Figure 19a:** Land use distribution in the Rotorua catchment 1940 (top) and 1958 (bottom).





**Figure 19b:** Land use distribution in the Rotorua catchment 1986 (top) and 1996 (bottom).



**Figure 19c:** Land use distribution in the Rotorua catchment 2001 (top) and 2003 (bottom).

**Table 8:** Area of various land use/cover classes 1940-2003.

LC	Area of land use/cover ha					
	1940	1958	1986	1996	2001	2003
BareGround	92	92	328	410	89	61
Cropping		6	6		9	209
ExoticForest	9681	10457	25925	26060	30600	29873
Horticulture	8			2	161	139
IndigenousForest	39076	41634	31288	30310	29565	28649
Beef						850
Dairy		6690				5777
DairyGrazers						881
Deer						1755
PastureExotic		2832	27329			
HighProducingGrassland					40442	17829
LowProducingGrassland					147	100
NonGrazedGrass						286
Grassland	33326	582				
Horses						265
Lifestyle						592
PrimePasture		1012	16695	44036		
SheepBeef						10721
Sheep						98
ExtensiveSheep		16820				
IntensiveSheep		8707				
TreesGrazed					969	2028
RuralRecreation						131
Scrub	23593	16087	2948	4003	2684	2872
MixedTrees	2304	67				1650
UrbanBuilt	566	2914	2913	2626	3143	2827
UrbanOpenSpace	190	859	938	914	845	768
SepticTanks						136
Water	14293	14284	14364	14349	14245	14315
Wetland	11	68	470	348	305	393
TotalPasture	33326	36643	44024	44036	41558	41182
IndigenousForest, Scrub & Wetland	62680	57789	34706	34661	32554	31914

### Point sources

There are three significant point sources of nitrogen in the catchment: septic tanks, geothermal inputs and sewage from the Rotorua sewage treatment plant.

Prior to completion of sewage reticulation, Hoare (1980) measured significantly higher concentrations of dissolved inorganic nitrogen (DIN) in urban streams than in rural streams, which he attributed to inputs from septic tanks. Hoare (1984) reports on studies in two residential areas (Pomare and Lynmore) on the outskirts of Rotorua

carried out in 1976-1977 while they were still serviced by septic tanks. He estimated the net increase in stream nitrogen flux from septic tanks to be 1.8 and 7.4 t yr<sup>-1</sup> in Pomare and Lynmore respectively. We determined the residential areas in each catchment from GIS maps in 1958 and 1986 which gave average values of 48 and 88 ha in Pomare and Lynmore respectively. Using these areas we estimate specific yields of 38 and 84 kgN ha<sup>-1</sup> yr<sup>-1</sup> in Pomare and Lynmore respectively. The uncertainty in residential area in 1976-1977 is high giving rise to a high uncertainty in specific nitrogen yield.

Census figures for 1956 – prior to sewage reticulation – give the total population in the catchment as 19,000. The GIS map for 1958 gives an urban built area (excluding urban open space) of 2,578 ha. The average nitrogen yield is 4 kgN capita<sup>-1</sup> yr<sup>-1</sup> (Hoare 1984) – range 2-6 kgN capita<sup>-1</sup> yr<sup>-1</sup>. From these figures we estimate a yield of 29 kgN ha<sup>-1</sup> yr<sup>-1</sup> which is comparable with the previous estimate of 38-84 kgN ha<sup>-1</sup> yr<sup>-1</sup>.

In the ROTAN simulations described below we used the average yield of 50 kgN ha<sup>-1</sup> yr<sup>-1</sup> for urban, rural and lakeside areas serviced by septic tanks. For urban areas after reticulation we assumed an average yield of 10 kgN ha<sup>-1</sup> yr<sup>-1</sup>, the ‘background’ level reported by Hoare (1984).

Since 1991 sewage from Rotorua City has been treated and then sprayed into Whakarewarewa Forest. Spraying increased from 1991-1992 to reach about 80 t N yr<sup>-1</sup> from 1993-2001. Plant upgrades at that time have seen a reduction to 40-60 t N yr<sup>-1</sup> from 2003-2006. There is significant storage and/or loss in the forest soils. Results of monitoring in the Waipa Stream showed a steady increase in nitrogen load leaving the RLTS from 1994-2001 – peaking at about 40 t N yr<sup>-1</sup> (leached). Plant upgrades have reduced this to about 30 t N yr<sup>-1</sup> from 2003-2006.

ROTAN simulates the Rotorua Land Treatment System (RLTS) as a load of 30 tN yr<sup>-1</sup> leaching from 220 ha at an average rate of 100 kgN ha<sup>-1</sup> yr<sup>-1</sup> for the period 1992-2008.

### **Nutrient attenuation**

Attenuation is the term applied to the temporary storage and/or permanent loss of nutrient between where it is generated in the catchment and where it enters the lake. Typically in large catchments about 50% of the nutrient export is attenuated before it leaves the catchment (Alexander et al. 2002). However, in some catchments attenuation can be negligibly small (Wilcock et al. 2006). The ROTAN simulations described below assume attenuation to be zero and the effect of this assumption is discussed.

## 5. Nutrient predictions

### Ngongotaha

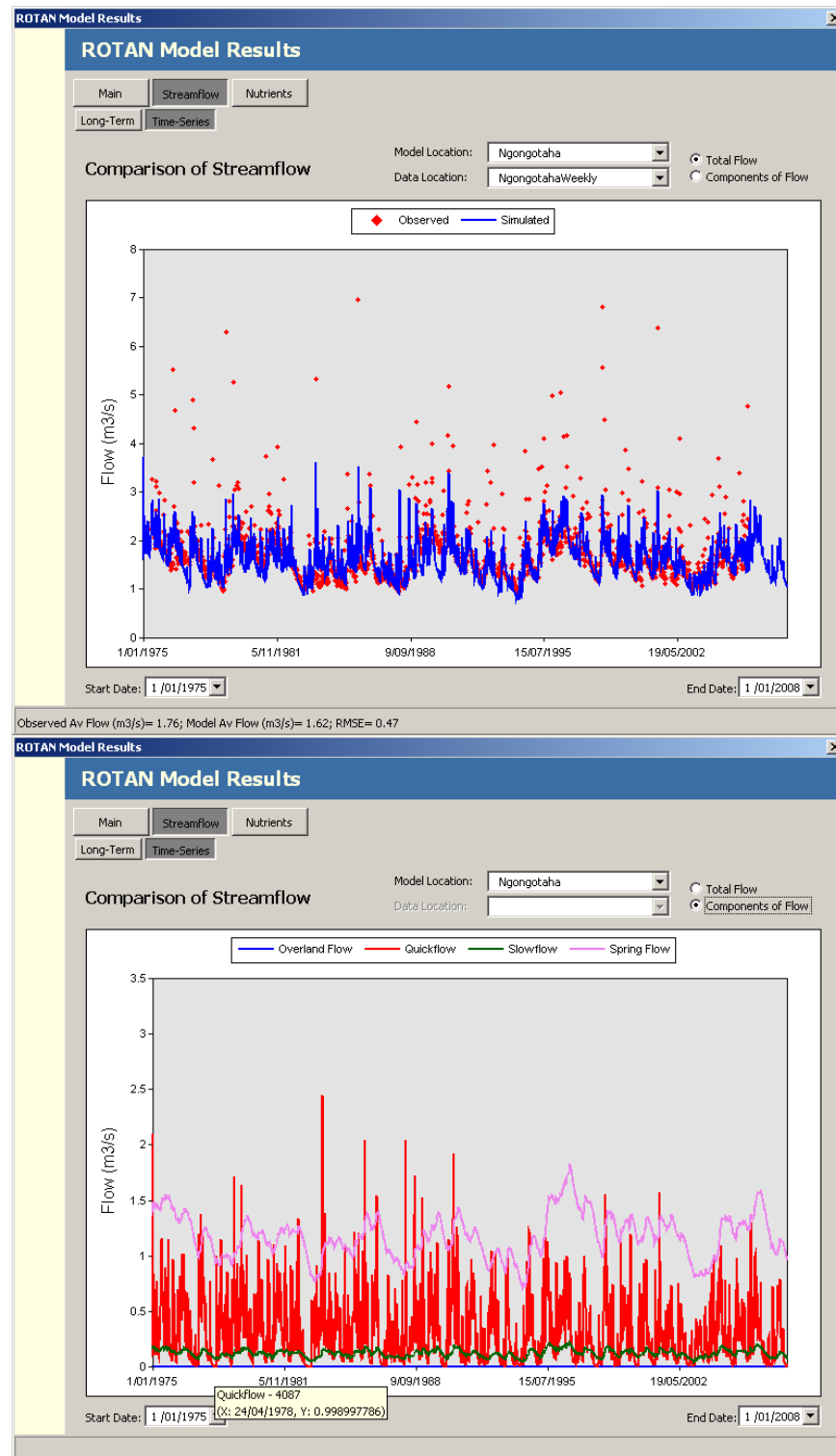
In the Ngongotaha catchment groundwater makes a significant contribution to stream flow (Figure 20 – see Spring Flow). Based on tritium measurements, groundwater is young (mean residence time (MRT) 15.5 years, Morgenstern and Gordon (2006)).

DIN ( $\text{NO}_3\text{N} + \text{NO}_2\text{N} + \text{NH}_4\text{N}$ )<sup>1</sup> concentrations are reported for 1976-1978 (Hoare 1980), 1987-1989 (Williamson et al. 1996) and 1993-2000 (EBoP unpublished data).  $\text{NH}_4\text{N}$  concentrations are negligibly small in Rotorua streams not affected by geothermal inflows. ROTAN predictions consistently exceed measured DIN (Figure 21) because concentrations of DON and PN are significant in the Ngongotaha Stream. ROTAN predictions match observations of TN ( $\text{DIN} + \text{DON} + \text{PN}$ ) in 1987-1989 and 1993-2000 tolerably well (Figure 21), and the few TN measurements in 1976-1978. Observed and predicted variability in nitrogen concentration are similar. This was achieved by assigning 70% of total nitrogen export to sub-layer 1 (near surface soils) and 15% each to the conceptual quickflow (sub-layer 3) and slowflow (sub-layer 4) reservoirs (Figure 3). Note that predictions and observations are both weekly averages.

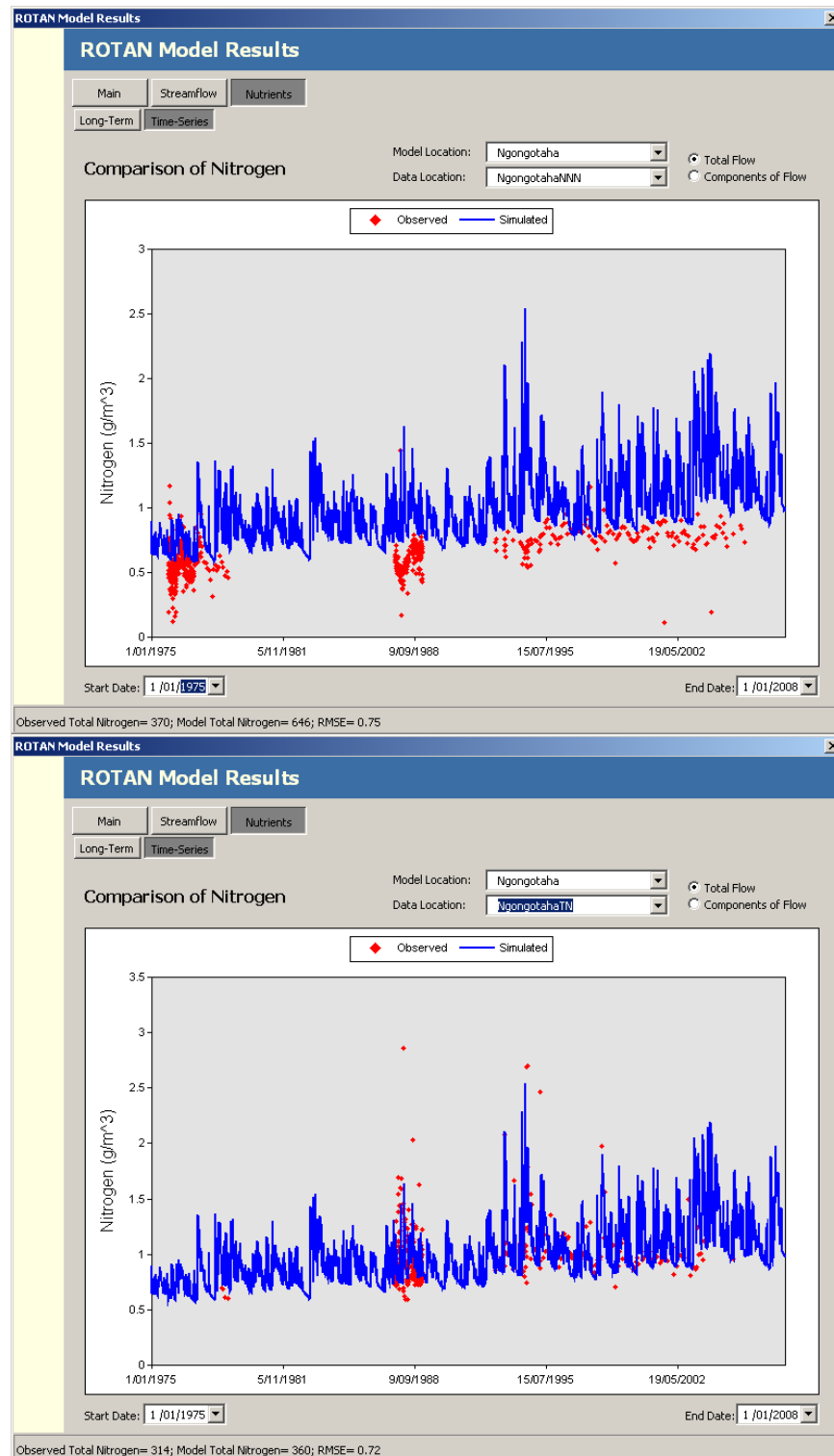
These results indicate that nitrogen exports from the land use types in the Ngongotaha catchment have been estimated tolerably well. Note that these simulations assume zero nitrogen attenuation. Land use in the Ngongotaha catchment is predominantly pasture with forest on Mt Ngongotaha and the eastern edge of the Mamaku Plateau (Figure 23). Land cover has not changed significantly since 1958 (Figures 19) although land use intensity has increased.

---

<sup>1</sup>  $\text{NO}_3\text{N}$  = nitrate-N,  $\text{NO}_2\text{N}$  = nitrite-N,  $\text{NH}_4\text{N}$  = ammonium-N, DON = dissolved organic nitrogen-N, PN = particulate nitrogen-N, DIN = dissolved inorganic nitrogen-N =  $\text{NO}_3\text{N} + \text{NO}_2\text{N} + \text{NH}_4\text{N}$ , and TN = total nitrogen-N =  $\text{NO}_3\text{N} + \text{NO}_2\text{N} + \text{NH}_4\text{N} + \text{DON} + \text{PN}$

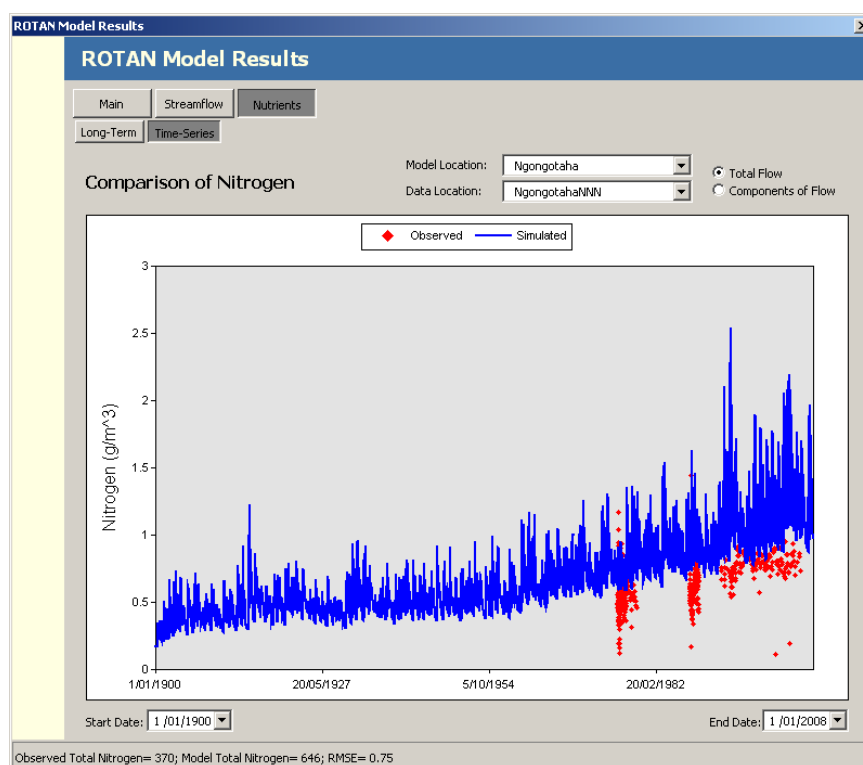


**Figure 20:** Observed and predicted weekly average flow in the Ngongotaha Stream (top) and the predicted flow components (bottom) 1975-2000. Note: figures need to be viewed in colour.



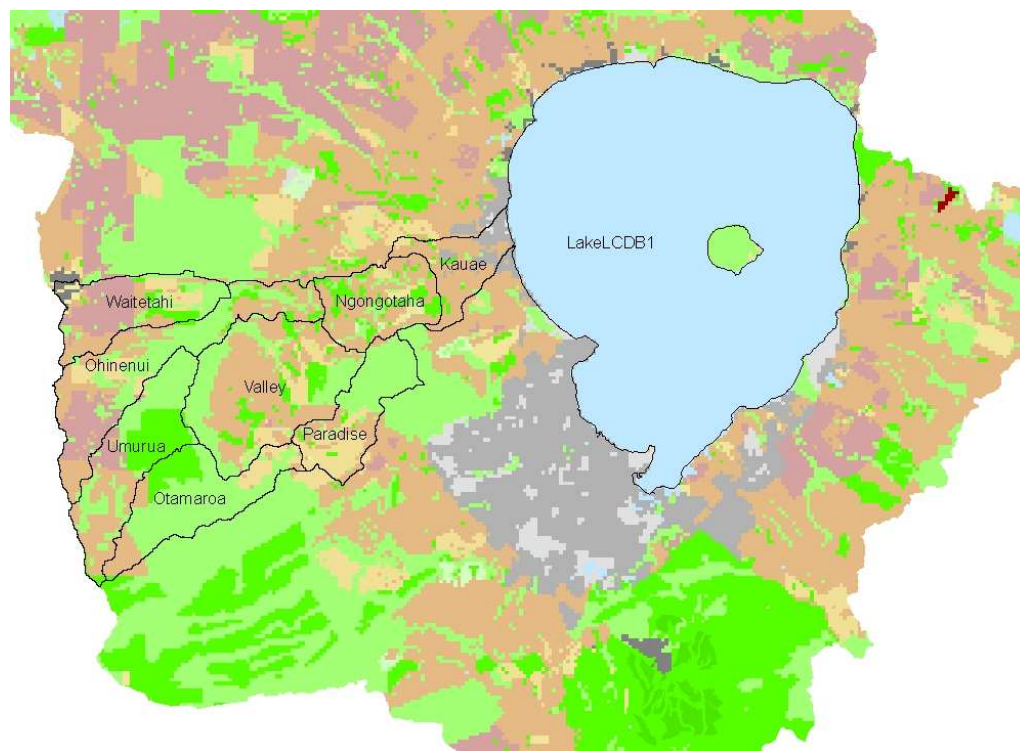
**Figure 21:** Comparisons between predicted TN concentrations and observed TN concentrations (bottom) and observed DIN concentrations (top) in the Ngongotaha Stream. Predictions and observations are weekly averages.

Figure 22 shows predicted TN concentrations 1900-2000. 1940 land use was assumed from 1900-1945 – an oversimplification – and the initial TN concentration of groundwater was set to  $0.17 \text{ g m}^{-3}$  based on the average concentration measured in deep, old groundwater (Uwe Morgenstern, GNS, *pers. comm.*). Stream concentrations respond quickly to land use change in the Ngongotaha where groundwater MRT (15.5 years) is the lowest measured at Rotorua. Predicted TN concentration increases from 1900-1905 which indicates that the specified initial groundwater concentration of  $0.17 \text{ g m}^{-3}$  is below the equilibrium value for the 1940 land use – closer to  $0.5 \text{ g m}^{-3}$ . It is desirable to estimate land use in 1900 consistent with groundwater concentrations of  $0.17 \text{ g m}^{-3}$ . Predicted concentrations in the 1970s are not strongly influenced by exports prior to the 1950s and the good fit between observed and predicted TN concentrations shown in Figure 21 tells us little about the accuracy of nitrogen export estimates from 1900-1950.



**Figure 22:** Comparisons between predicted TN concentrations and observed DIN concentrations in the Ngongotaha Stream 1900-2000.





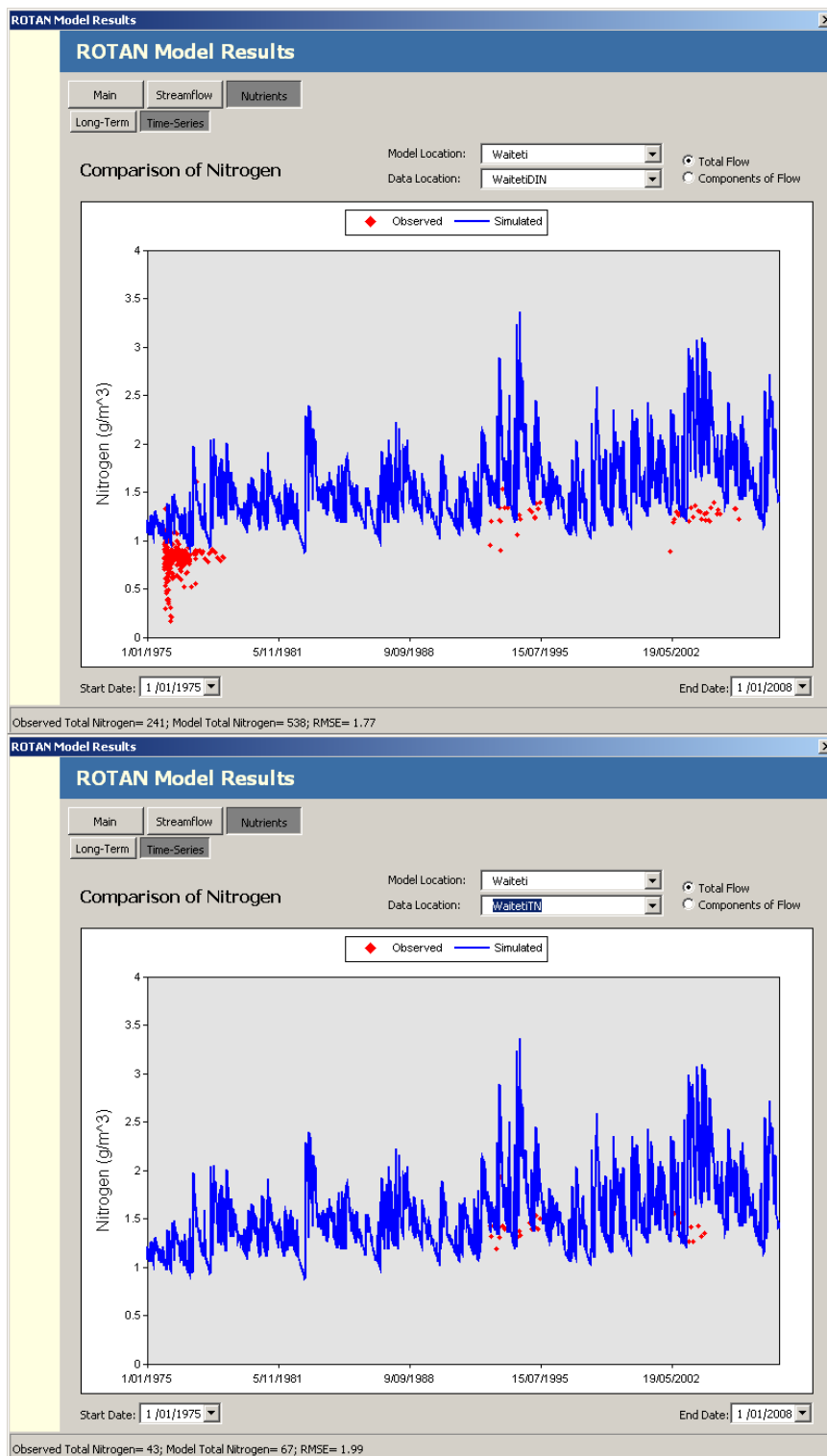
**Figure 23:** Land use in 2001 in the surface catchments of the Ngongotaha Stream. Land cover in the Ngongotaha is similar in 1958, 1986, 1996, 2001 and 2003 although land use intensity has increased. See Figures 19 for the land use legend.

### Waiteti

The Waiteti catchment contains roughly equal proportions of pasture and forest. Water yield in the Waiteti Stream is very low (Table 1), which indicates that much of the drainage from the Waiteti emerges as springflow outside the surface catchment.

In the ROTAN simulations, groundwater flows NE from the Waitetahi to the Waiteti, and NE from the Waipapa to the Awahou (Figure 4). Mean residence time of groundwater in the Waiteti is 40 years (Morgenstern and Gordon 2006).

Observed and predicted TN concentrations in 1991-1995 match tolerably well (Figure 24), but there are no TN measurements in 1976-1977 to compare with predictions. Predicted TN consistently exceeds measured DIN as expected (Figure 24). There is an increasing trend in predicted TN concentration which broadly matches increasing trends in measured DIN.



**Figure 24:** Comparisons between predicted TN concentrations and observed TN concentrations (bottom) and observed DIN concentrations (top) in the Waiteti Stream. Predictions and observations are weekly averages.

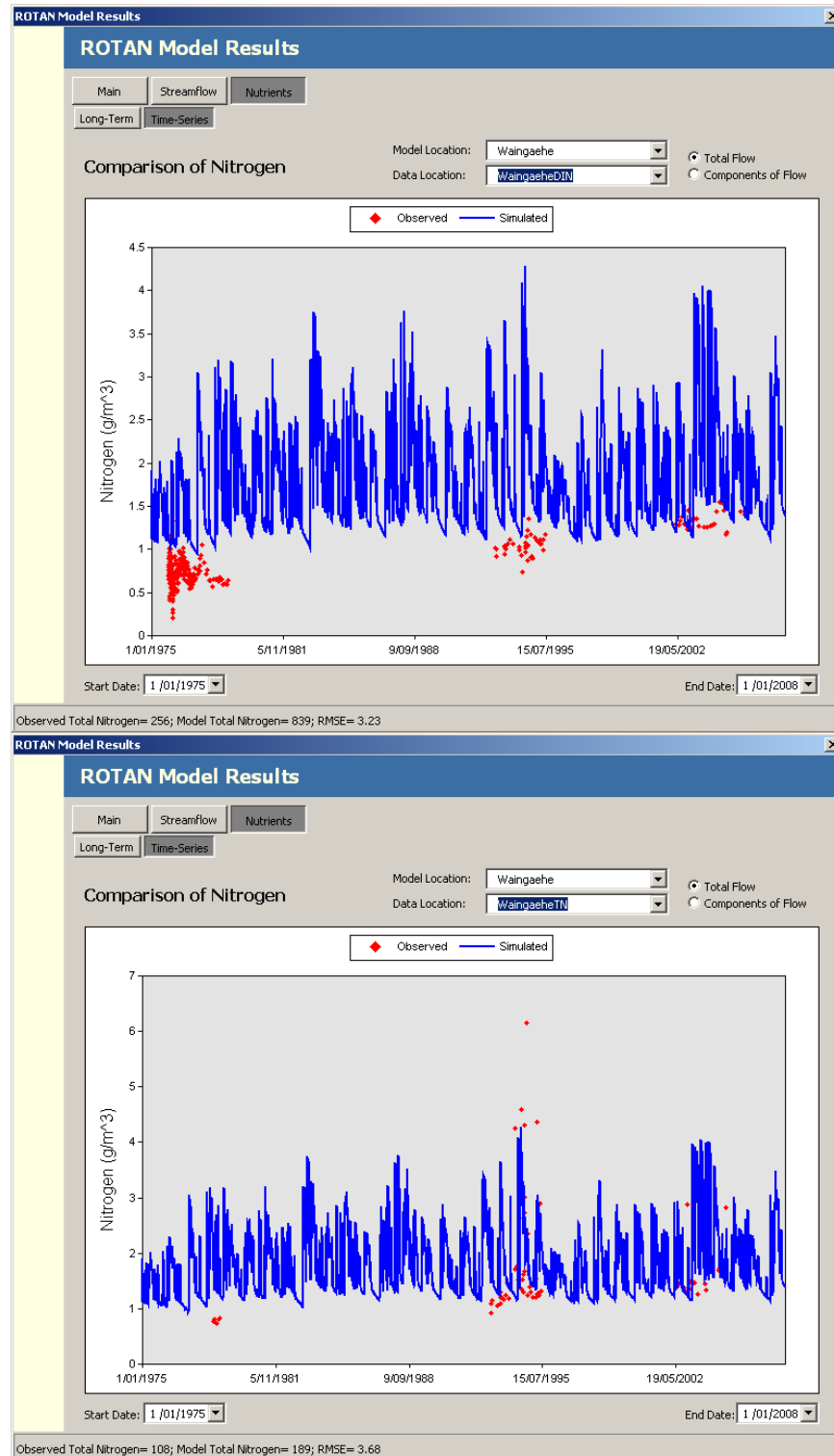
## Waingaehe

The Waingaehe catchment is predominantly pasture with some forest (Figure 19). Mean residence time of groundwater in the Waingaehe is 127 years (Morgenstern and Gordon 2006) – the longest measured in all Lake Rotorua catchments.

Predicted TN concentrations consistently exceed observed DIN concentrations – as expected. The observed increasing trend in DIN concentrations is broadly matched by the predicted increasing trend in TN concentration (Figure 25).

Predicted TN concentrations are slightly higher than observed TN concentrations in 1977 and are comparable in 1991-1995 (Figure 25). ROTAN predicts similar variability in TN concentration to the observations.

Simulations in the Waiteti and Waingaehe provide additional support for the nitrogen exports and groundwater travel times in ROTAN.



**Figure 25:** Comparisons between predicted TN concentrations and observed TN concentrations (bottom) and observed DIN concentrations (top) in the Waingaehe Stream. Predictions and observations are weekly averages.

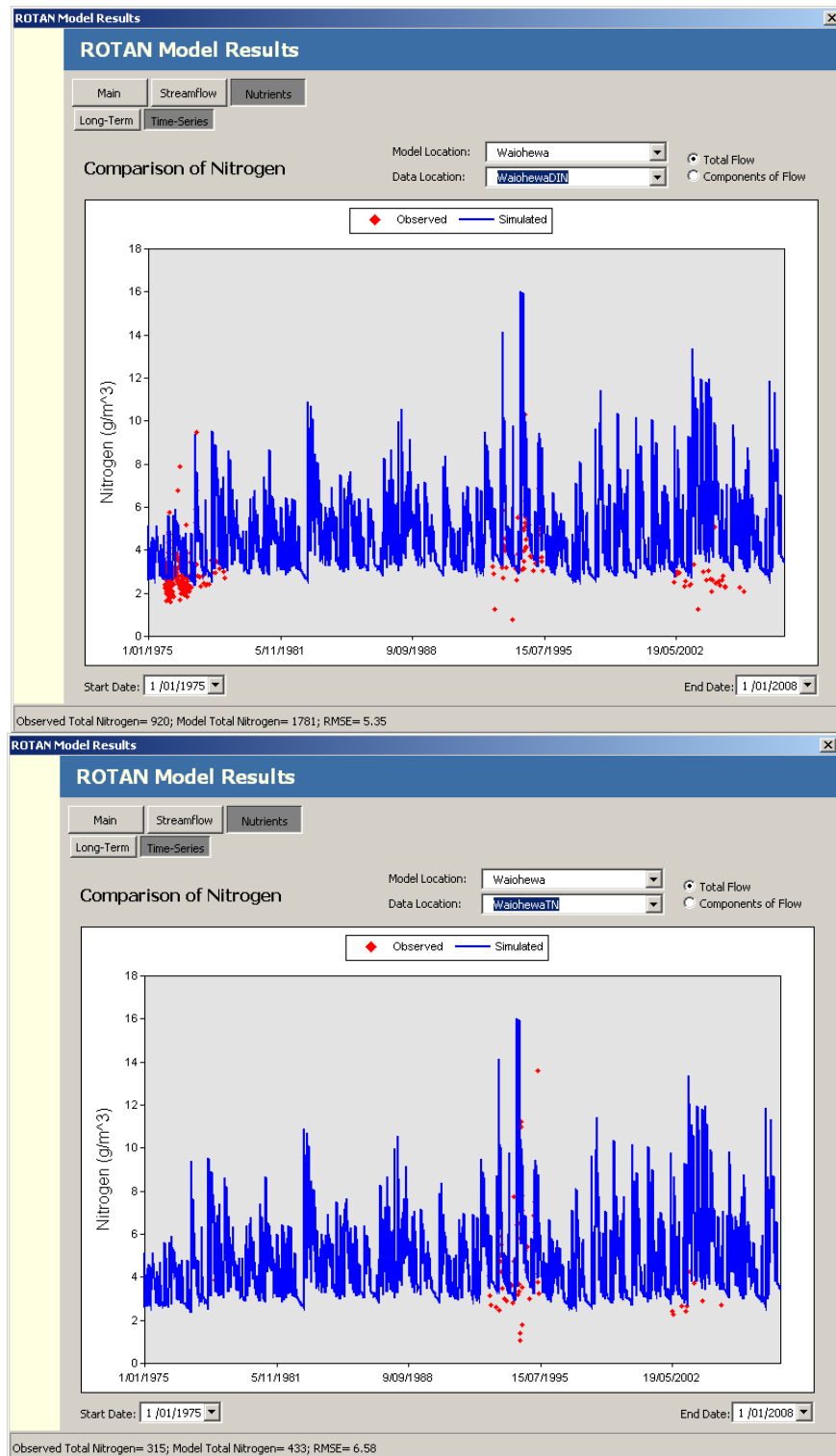
### **Waiohewa**

DIN concentrations in the Waiohewa are strongly influenced by geothermal inflows from Tikitere and  $\text{NH}_4\text{N}$  concentrations are high. ROTAN includes a geothermal load of  $50 \text{ tN yr}^{-1}$ . Predicted TN concentrations match observed TN and DIN concentrations in 1976-1977 and 1991-1995 tolerably well (Figure 26).

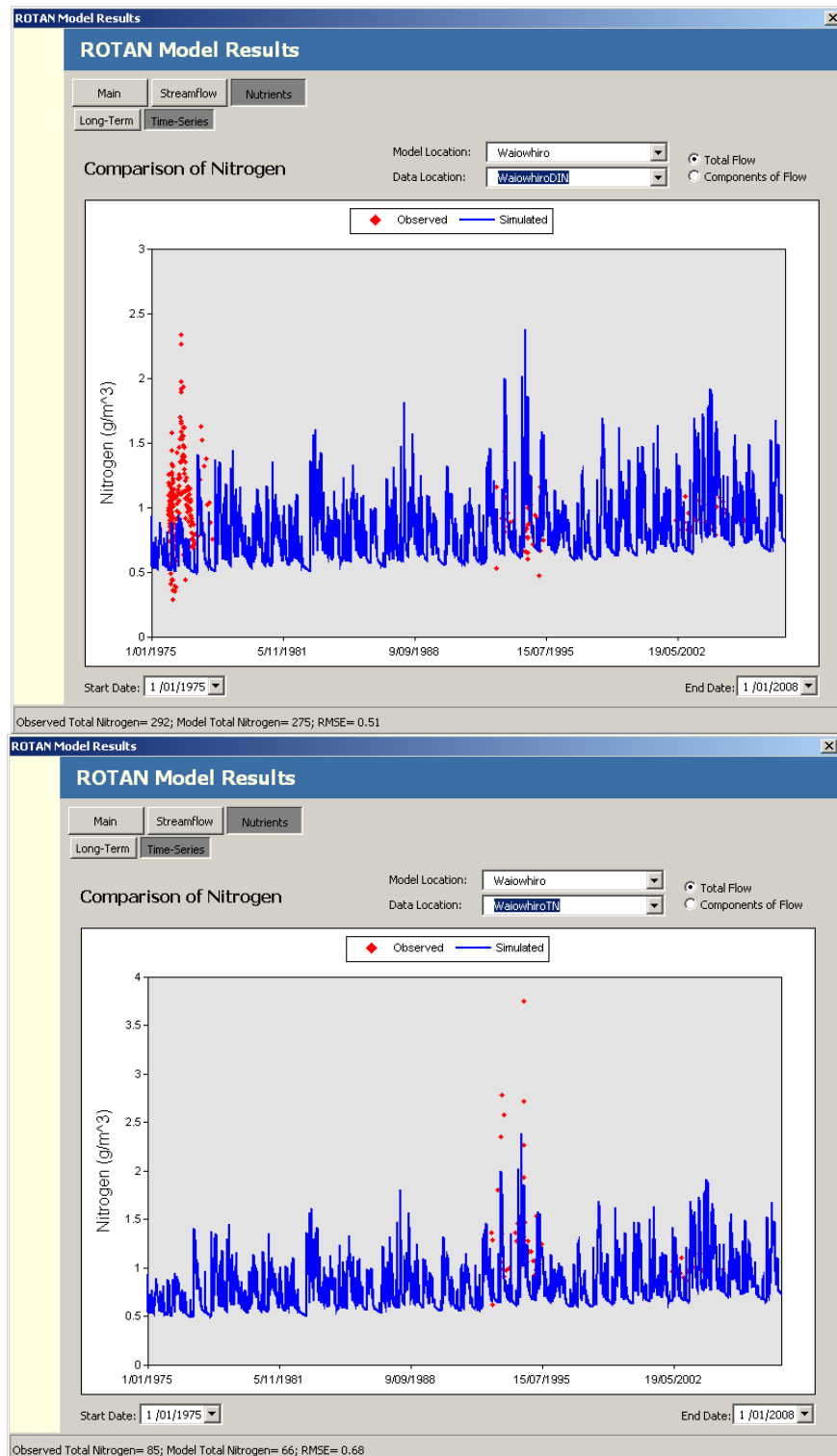
### **Waiowhoro**

The Waiowhoro catchment contains the Rainbow/Fairy Springs and a satisfactory water balance could only be achieved by including groundwater inflows from parts of the Paradise and Mangakakahi surface catchments (Figures 2 and 4). Land use is roughly equal proportions of forest/scrub, pasture and urban, and groundwater MRT is 42 years.

Predicted TN concentrations match observations in 1991-1995 tolerably well, with similar variability (Figure 27). Predicted TN concentrations are slightly lower than observed DIN concentrations in 1976-1977, with lower short-term variability. However, in 1991-1995 these relationships are reversed.



**Figure 26:** Comparisons between predicted TN concentrations and observed TN concentrations (bottom) and observed DIN concentrations (top) in the Waiohewa Stream. Predictions and observations are weekly averages.



**Figure 27:** Comparisons between predicted TN concentrations and observed TN concentrations (bottom) and observed DIN concentrations (top) in the Waiowhoro Stream. Predictions and observations are weekly averages.

## **Utuhina**

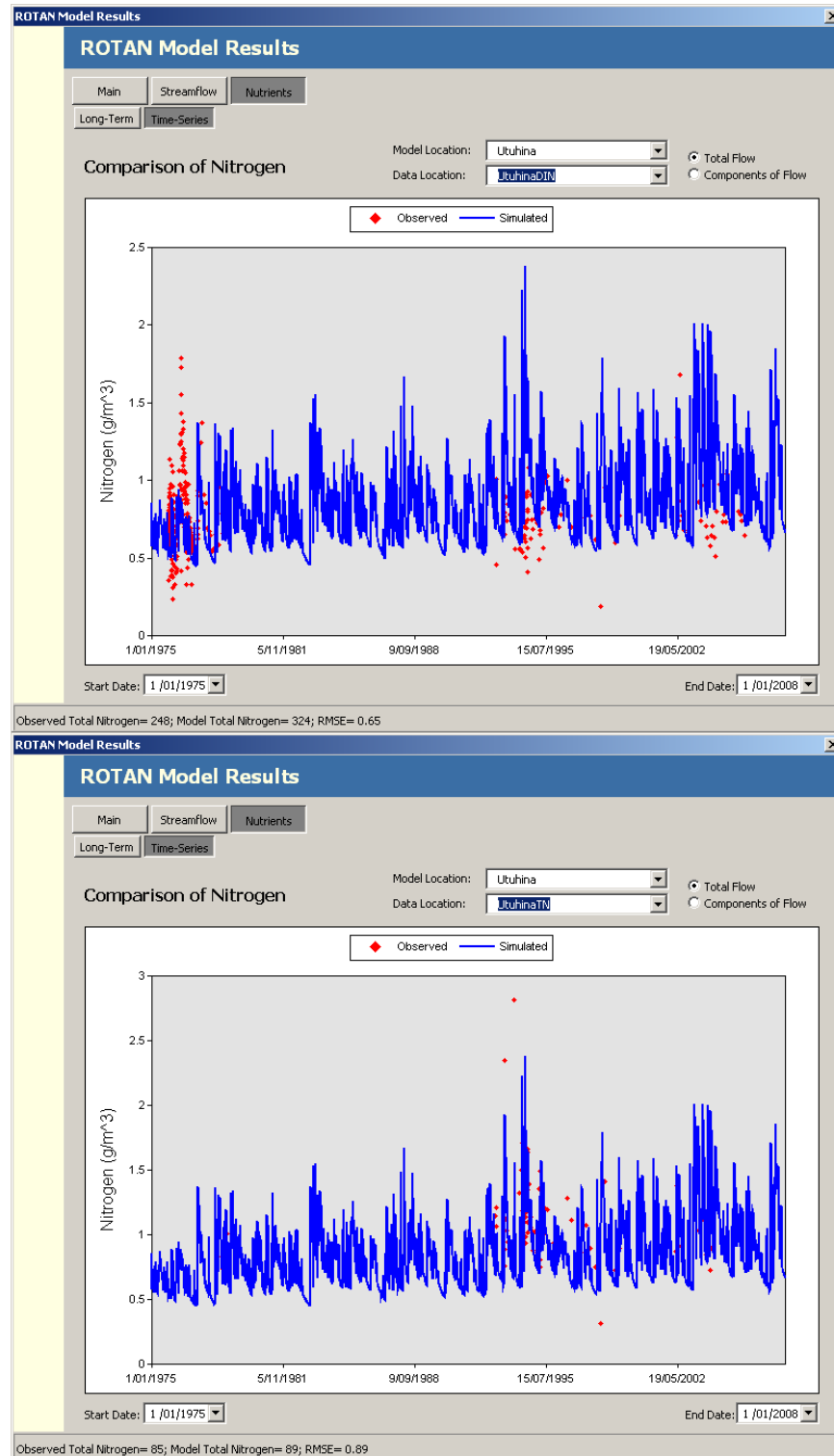
Land use in the Utuhina is roughly equal proportions of forest, pasture and urban land. Groundwater MRT is 48 years and there are springs on the outskirts of Rotorua City. Observed and predicted TN concentrations match tolerably well in 1992-1997 (Figure 28) but there are very few TN measurements in 1976-1977. Predicted TN concentrations are comparable with observed DIN concentration in both 1976-1977 and 1992-1997. This arises because DON and PN concentrations in the Utuhina are low.

## **Puarenga**

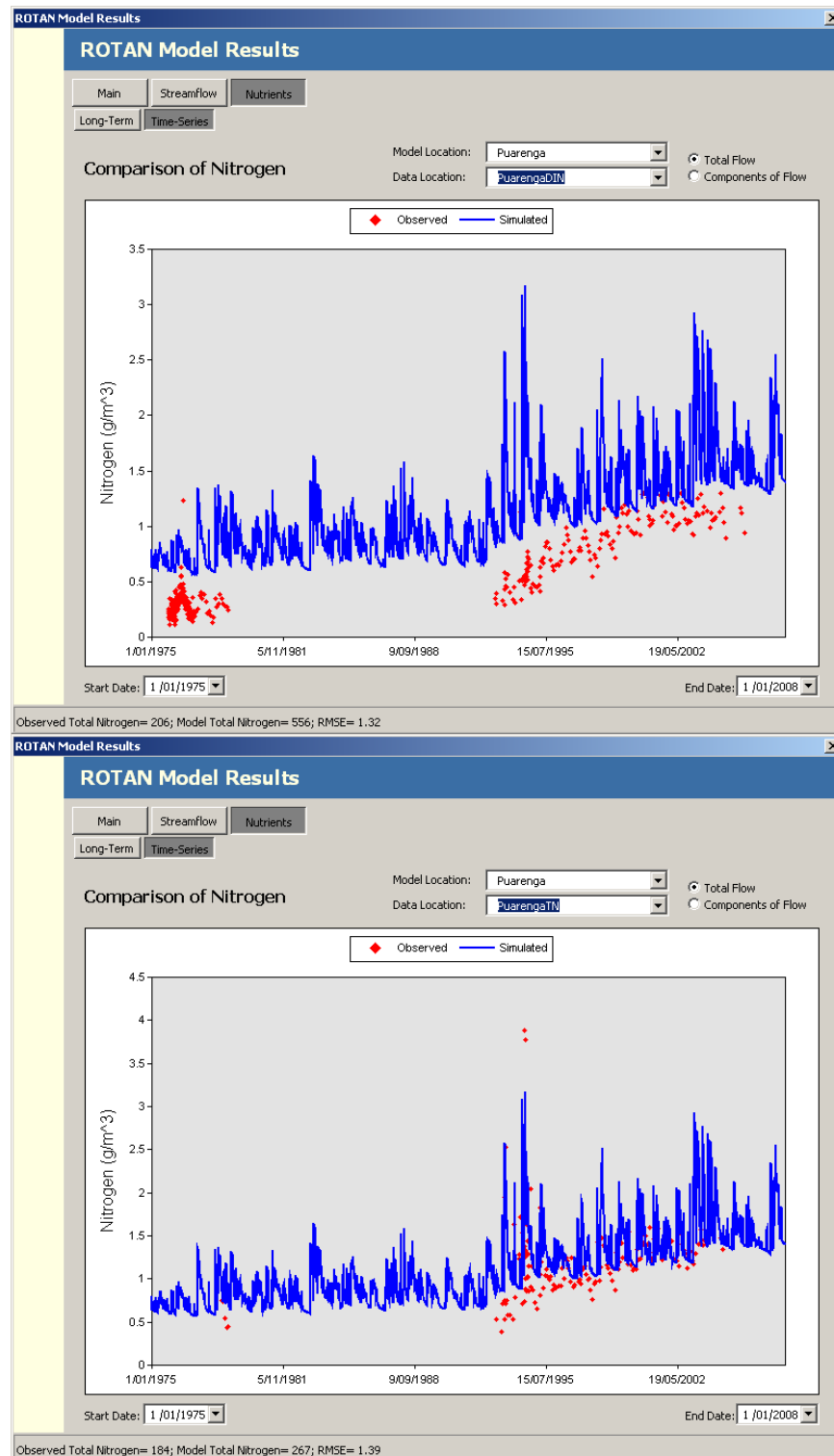
The Puarenga catchment contains roughly equal proportions of pasture and exotic forest and, since 1991, the RLTS. Groundwater MRT for the whole catchment is 37 years (Morgenstern and Gordon 2006). Commencing in 1991, treated sewage has been sprayed in the Waipa sub-catchment of Whakarewarewa Forest. Stream monitoring results for chloride and nitrate are consistent with the Waipa catchment having a groundwater MRT of about 5 years (Ray and Rutherford 2004).

Predicted TN concentrations slightly over-estimate the small number of observed TN concentrations in 1977 and 1992 (Figure 29). From 1993-2000 predicted TN concentrations are comparable with observed TN concentrations. Observed DIN concentrations are lower than predicted TN concentrations in the Puarenga where DON and PN concentrations are significant. Observed and predicted TN concentrations both increased significantly from 1992-2000 as a result of the RLTS.





**Figure 28:** Comparisons between predicted TN concentrations and observed TN concentrations (top) and observed DIN concentrations (bottom) in the Utuhina Stream. Predictions and observations are weekly averages.



**Figure 29:** Comparisons between predicted TN concentrations and observed TN concentrations (bottom) and observed DIN concentrations (top) in the Puarenga Stream. Predictions and observations are weekly averages.

## **Awahou**

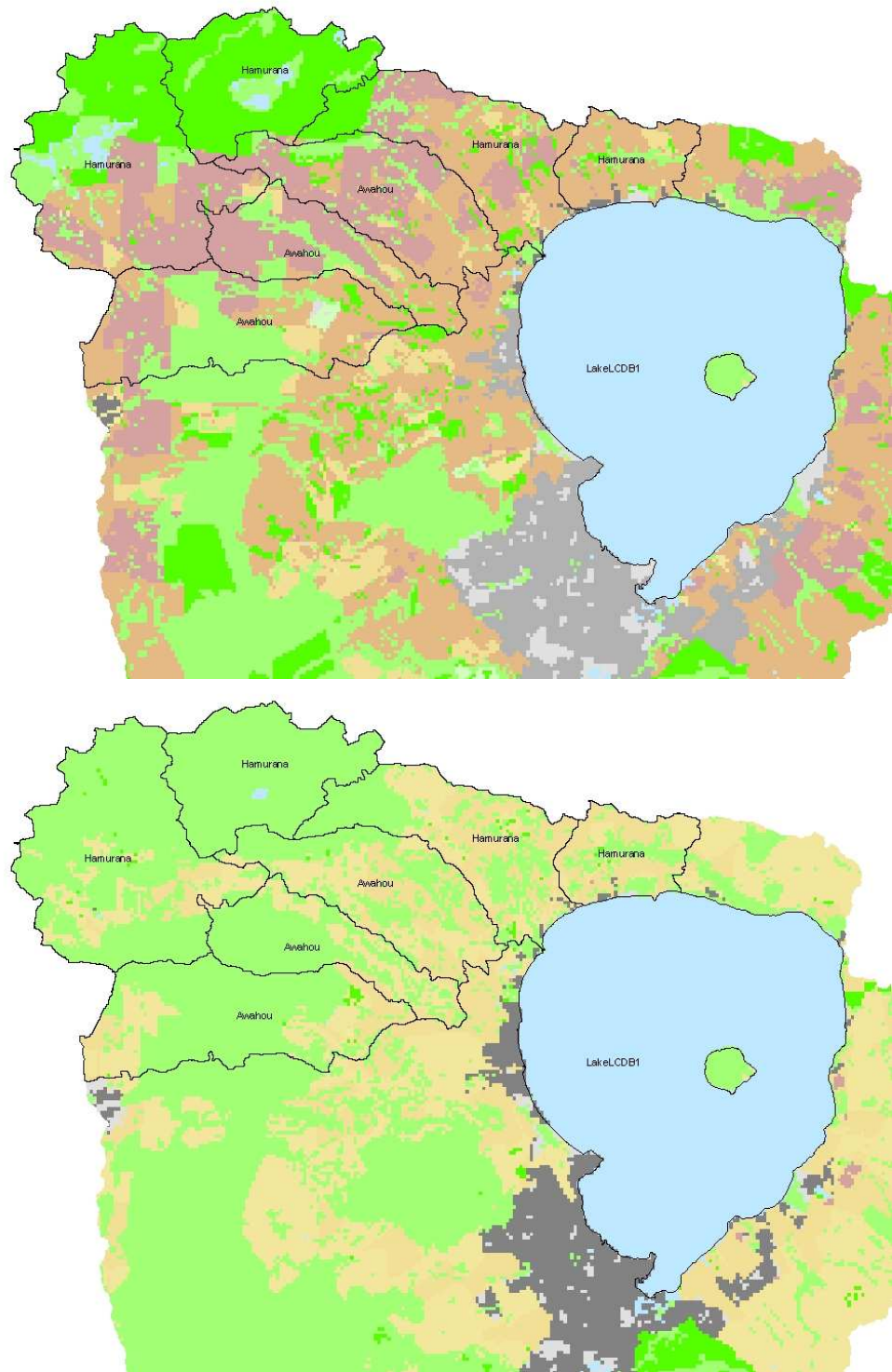
The Awahou groundwater catchment is predominantly pasture with some forestry on its southern boundary (Figure 30). It contains the Taniwha springs complex whose waters have an MRT of 61 years (Morgenstern and Gordon 2006). There is an increasing trend in predicted TN concentration associated with the combination of land use intensification in the 1950s and groundwater lags of 60 years. Predicted TN concentrations in 1991-1995 are comparable with observations (Figure 31). However, predicted TN concentrations significantly underestimate observed DIN observations in 1975-1977. Since  $TN > DIN$  this implies that ROTAN also underestimates TN in that period.

There are two possible explanations. First, ROTAN may over-estimate groundwater lag times in the Awahou. Currently ROTAN matches the mean residence time measured by Morgenstern and Gordon (2006) which quantifies the travel time for tritium in rain water assumed to be distributed uniformly across the whole catchment. It is conceivable, however, that intensive land uses are concentrated close to the Awahou springs and that nitrate finds its way to the springs more quickly than the MRT of 60 years suggests. If this is true then land use intensification just after WWII would have increased nitrogen concentrations in the Awahou more quickly than is currently modelled. Second, ROTAN may underestimate nitrogen leaching rates in the Awahou through inaccuracies in estimating when land use intensification occurred. Thus nitrogen leaching rate may have increased more quickly after WWII than indicated by Table 6.

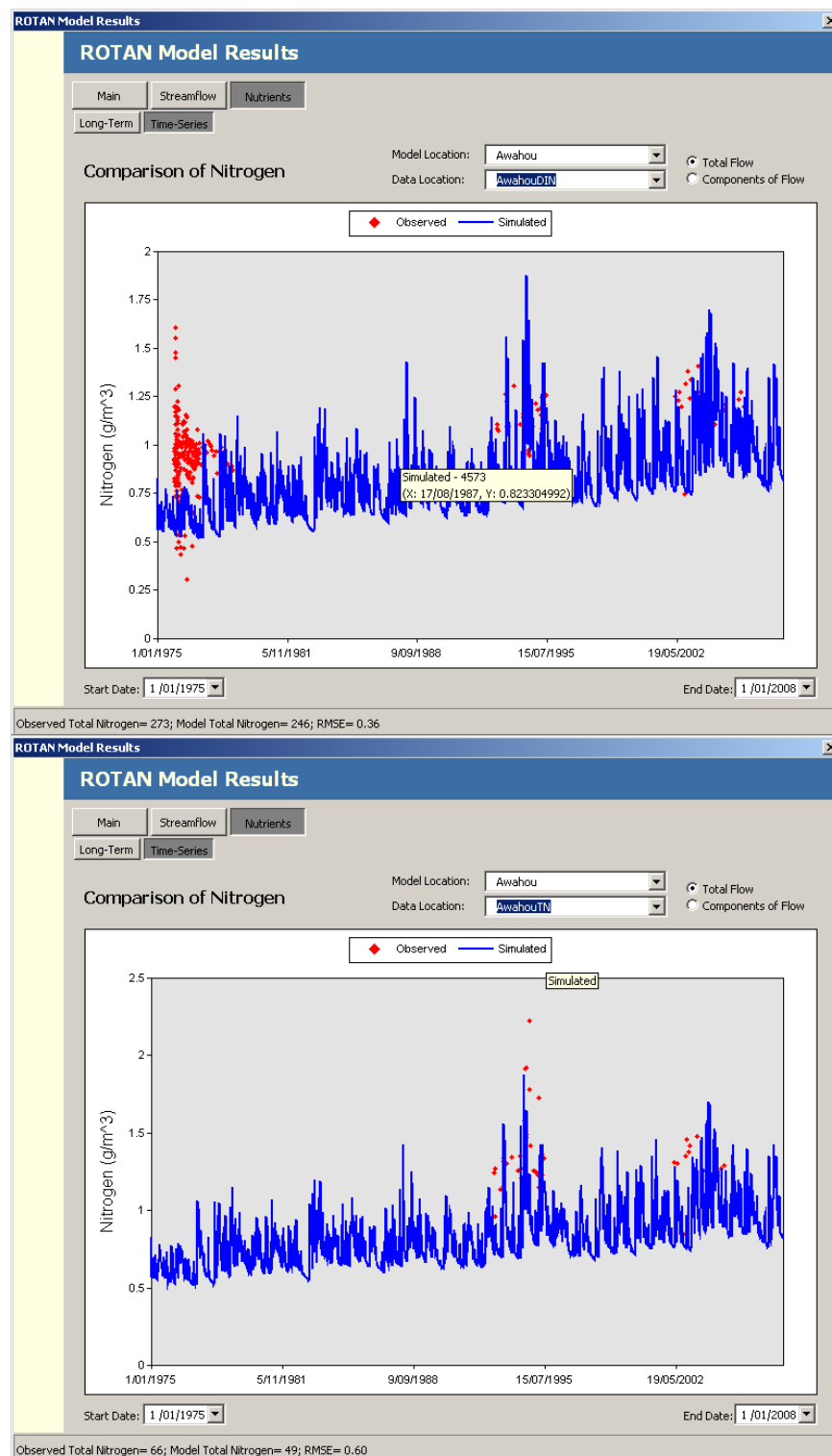
## **Hamurana**

The Hamurana catchment contains a mix of pasture and forest. As modelled in ROTAN the sequence of catchments Mamaku – Hiwiroa – Hauraki – Hamurana feeds the Hamurana Springs whose waters have an MRT of 110 years (Morgenstern and Gordon 2006). The surface catchments closest to the Hamurana Springs (Hauraki and Hamurana) are predominantly pasture, as is the surface catchment farthest away (Mamaku), while the Hiwiroa is predominantly forest (Figure 30).

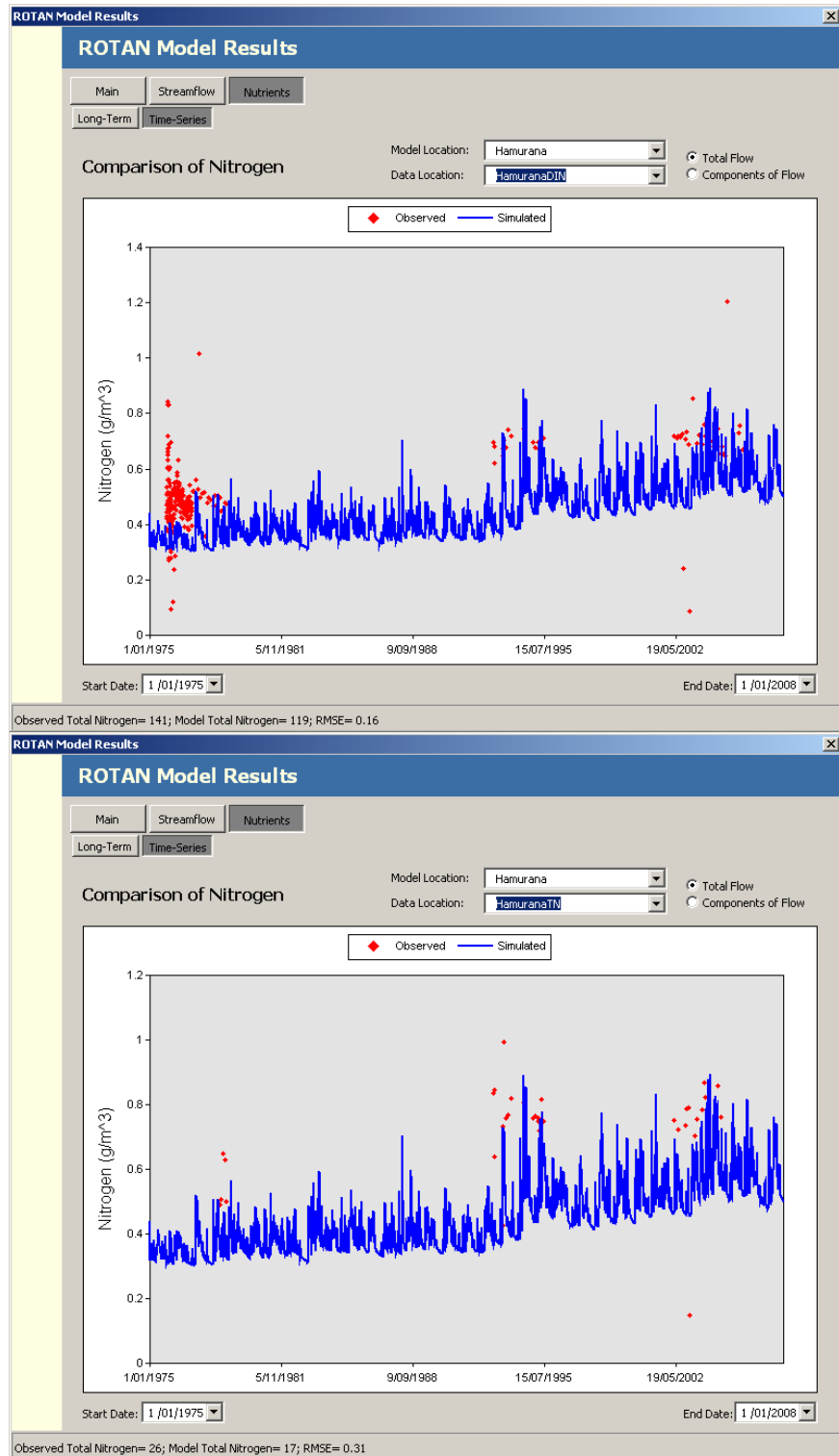
Observed TN concentrations in 1991-1995 are higher than predictions, as are the few observations in 1978 (Figure 32). Observed DIN concentrations in 1975-1978 are higher than predicted TN concentrations and since  $TN > DIN$  this implies that ROTAN underestimates TN concentration during this period. As with the Awahou, ROTAN may over-estimate groundwater lag times and/or under-estimate nitrogen leaching rates in the Hamurana. It is also possible that the boundaries of the Hamurana aquifers may not be located correctly. Moving the boundaries to include more pasture in the Awahou and/or north of the external boundary would increase nitrogen inputs to the Hamurana.



**Figure 30:** Land use in the Hamurana and Awahou groundwater catchments 2001 (top) and 1958 (bottom). See Figures 19 for the land use legend.



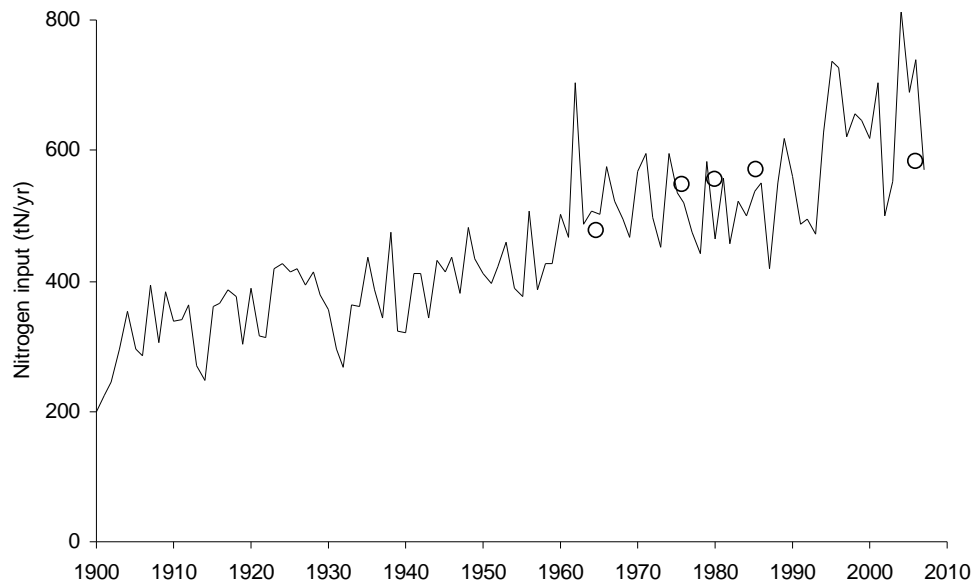
**Figure 31:** Comparisons between predicted TN concentrations and observed TN concentrations (bottom) and observed DIN concentrations (top) in the Awahou Stream. Predictions and observations are weekly averages.



**Figure 32:** Comparisons between predicted TN concentrations and observed TN concentrations (bottom) and observed DIN concentrations (top) in the Hamurana Stream. Predictions and observations are weekly averages.

### Lake input

Figure 33 shows ROTAN predictions of the total nitrogen input to the lake from streams, to which has been added 30 tN yr<sup>-1</sup> for rain falling on the lake. Also shown are previously published estimates of lake input including rain on the lake. The most reliable of these is the estimate for 1976-1977 by Hoare (1980). The estimates for 1965, 1981 and 1985 (Rutherford et al. 1989) use Hoare's stream and rainfall loads but account for changes in sewage inputs. The estimates for 2005 (Morgenstern and Gordon 2006) are based on groundwater dating studies. Overall there is reasonable agreement between observed and predicted total lake inputs.



**Figure 33:** Annual nitrogen input to Lake Rotorua for 1900-2000 predicted using the ROTAN model (—). Also shown (O) are previous published estimates.

## 6. Discussion and conclusions

The ROTAN model has been calibrated for the Lake Rotorua catchment and a satisfactory fit achieved for the long-term water balance, previously published estimates of nitrogen input to the lake, and measured TN concentrations in the major streams. The earliest stream measurements used were from 1976-1977 (Hoare 1980) and ROTAN cannot be verified prior to the 1970s. Fish (1975) measured inorganic nutrient concentrations in major streams from 1968-1970 but these data have not yet been used for ROTAN calibration or testing.

The ROTAN simulations in this report assume zero attenuation. The satisfactory match in Figure 33 indicates that either: nitrogen exports have been under-estimated and attenuation is non-zero, or nitrogen exports have been estimated correctly and attenuation is negligible. If the latter is true then there may be limited opportunities to increase nutrient attenuation in the catchment by intercepting nitrogen after it has been exported from the land (e.g., enhancing nitrogen removal in riparian buffers or enhancing natural wetlands). However, mitigation can reduce nitrogen exports (e.g., through reduced stocking rates in winter, use of herd homes and careful application of fertiliser).

The current ROTAN simulations use the best available estimates of aquifer boundaries. GNS-Science played the major role in identifying these boundaries. ROTAN has been used to refine the GNS boundaries to achieve satisfactory water balances for the lake and individual streams. There is still some uncertainty about the location of these boundaries.

The current ROTAN simulations use the groundwater mean residence times (MRT) determined by Morgenstern and Gordon (2006) using tritium. However, it was not possible to satisfactorily match observed nitrogen concentrations in the Awahou and Hamurana catchments which both have old groundwater [MRT 60 years (Awahou) and 110 years (Hamurana)]. ROTAN simulates 3 (Awahou) and 4 (Hamurana) sub-aquifers in series whose parameters were adjusted to match Morgenstern's mean residence times. The same MRT in the Awahou and Hamurana can be achieved with different combinations of MRTs in the sub-aquifers. It was not possible to match observed nitrogen concentrations using identical parameters in each sub-aquifer. An improved, but still not completely satisfactory, match was obtained assuming that sub-aquifer volume increased with distance from the lake.

ROTAN currently assumes a single aquifer layer. In reality the aquifer could be multi-layered – making this refinement could improve model accuracy provided information exists to support a multi-layer calibration.



Predicted nitrogen concentrations in the Awahou and Hamurana are very sensitive to uncertainties in sub-aquifer boundaries, the history of land use intensification, and MRTs. It is important for EBoP, when considering land use control measures, that the aquifer boundaries be determined as accurately as possible. Further work is desirable to refine the boundaries and volumes of the sub-aquifers. Stream nitrogen measurements combined with historic land use information and stocking rates could be used to test and refine the current boundaries and MRT estimates made using tritium. Ideally this work should be done in collaboration with GNS-Science.

## 7. Acknowledgements

Paul White, Uwe Morgenstern and Timothy Hong, GNS-Science, collaborated throughout this study and provided data on geology and groundwater and advice about infiltration, groundwater catchments and water budgets. Dougal Gordon and Paul Dell, EBoP, provided data and guidance. Bob Murray and Wayne McGrath, NIWA, Rotorua provided advice and information about hydrology. Dan Rucinski, LimnoTech, Michigan, coded the ROTAN model and remotely fixed bugs. This study was funded partly by EBoP through contract BOP05225 and partly by the Foundation for Research, Science and Technology through Contract C01X0304.

## 8. Appendix 1: Rules for predicting land use from land cover

The following VBA code is implemented with Excel

```

Private Sub CommandButton1_Click()
    Dim LU1940(55000), LU1958(55000), LU1986(55000) As String
    Dim LU1996(55000), LU2001(55000), LU2003(55000), Parcel(55000) As String
    Dim LUNew1940(55000), LUNew1958(55000), LUNew1986(55000) As String
    Dim LUNew1996(55000), LUNew2001(55000), LUNew2003(55000) As String
    Dim I, NumObs As Integer
    Application.ScreenUpdating = False
    NumObs = 17010
    Sheets("LC_All_R2P_Int6").Select
    Worksheets("LC_All_R2P_Int6").Range("O2:U20000").Clear
    Worksheets("LC_All_R2P_Int6").Range("z2:am20000").Clear
    Range("b2").Select
    For I = 1 To NumObs
        LU1940(I) = ActiveCell.Value
        ActiveCell.Offset(0, 1).Select
        LU1958(I) = ActiveCell.Value
        ActiveCell.Offset(0, 1).Select
        LU1986(I) = ActiveCell.Value
        ActiveCell.Offset(0, 1).Select
        LU1996(I) = ActiveCell.Value
        ActiveCell.Offset(0, 1).Select
        LU2001(I) = ActiveCell.Value
        ActiveCell.Offset(0, 1).Select
        LU2003(I) = ActiveCell.Value
        ActiveCell.Offset(0, 3).Select
        Parcel(I) = ActiveCell.Value
        ActiveCell.Offset(1, -8).Select
    Next I

    For I = 1 To NumObs
        If LU1940(I) = "MixedTrees" Then LU1940(I) = "IndigenousForest"
        If LU1958(I) = "MixedTrees" Then LU1958(I) = "IndigenousForest"
        If LU1986(I) = "MixedTrees" Then LU1986(I) = "ExoticForest"
        If LU1996(I) = "MixedTrees" Then LU1996(I) = "ExoticForest"
        If LU2001(I) = "MixedTrees" Then LU2001(I) = "ExoticForest"
        If LU2003(I) = "MixedTrees" Then LU2003(I) = "ExoticForest"
    Next I

    For I = 1 To NumObs
        If LU2003(I) = "Outside" Then LU2003(I) = LU2001(I)
    Next I

    For I = 1 To NumObs
        If LU1986(I) = "Outside" Then LU1986(I) = LU1996(I)
    Next I

    For I = 1 To NumObs
        If LU1958(I) = "Outside" Then LU1958(I) = LU1940(I)
    Next I

    For I = 1 To NumObs
        If LU1958(I) = "Outside" Then LU1958(I) = LU1986(I)
    Next I

    For I = 1 To NumObs
        If LU1958(I) = "Outside" Then LU1958(I) = LU1996(I)
    Next I

```

```

For I = 1 To NumObs
If LU1940(I) = "Outside" Then LU1940(I) = LU1958(I)
Next I
For I = 1 To NumObs
If LU2003(I) = "Road" Then LU2003(I) = LU2001(I)
Next I
For I = 1 To NumObs
If LU1958(I) = "Other" Then
    If LU1940(I) = "Urban" Or LU1940(I) = "UrbanOpenSpace" Then LU1958(I) = LU1940(I)
End If
If LU1958(I) = "Other" Then
    If LU1986(I) = "Urban" Or LU1986(I) = "UrbanOpenSpace" Then LU1958(I) = "UrbanOpenSpace"
End If
If LU1958(I) = "Other" Then LU1958(I) = LU1986(I)
Next I
For I = 1 To NumObs
If LU1940(I) = "Other" Then LU1940(I) = LU1958(I)
Next I
For I = 1 To NumObs
If LU2003(I) = "Other" Then LU2003(I) = LU2001(I)
Next I
For I = 1 To NumObs
If LU2003(I) = "Urban" And LU2001(I) = "UrbanOpenSpace" Then LU2003(I) = LU2001(I)
Next I
For I = 1 To NumObs
If LU1958(I) = "Dairy" Or LU1958(I) = "ExtensiveSheep" Or LU1958(I) = "IntensiveSheep" Or LU1958(I) =
"Grassland" Then
    If LU1986(I) = "IndigenousForest" Or LU1986(I) = "Scrub" Or LU1986(I) = "Wetland" Or LU1986(I) =
"ExoticForest" Then
        If LU1996(I) = "IndigenousForest" Or LU1996(I) = "Scrub" Or LU1996(I) = "Wetland" Then
            LU1958(I) = LU1986(I)
        End If
    End If
End If
Next I
For I = 1 To NumObs
If LU1940(I) = "Dairy" Or LU1940(I) = "ExtensiveSheep" Or LU1940(I) = "IntensiveSheep" Or LU1940(I)
= "Grassland" Then
    If LU1958(I) = "IndigenousForest" Or LU1958(I) = "Scrub" Or LU1958(I) = "Wetland" Or LU1958(I) =
"ExoticForest" Then LU1940(I) = LU1958(I)
End If
Next I
For I = 1 To NumObs
If LU1996(I) = "PrimePasture" Then
If LU2003(I) = "IndigenousForest" Or LU2003(I) = "ExoticForest" Then
If LU2001(I) = "IndigenousForest" Or LU2001(I) = "ExoticForest" Then
LU2001(I) = "TreesGrazed"
LU2003(I) = "TreesGrazed"
End If
End If
End If
Next I
For I = 1 To NumObs
If LU1996(I) = "PrimePasture" Then
If LU2003(I) = "Beef" Or LU2003(I) = "Dairy" Or LU2003(I) = "DairyGrazers" Or LU2003(I) = "Deer" Or
LU2003(I) = "Horses" Or LU2003(I) = "Sheep" Or LU2003(I) = "SheepBeef" Then
If LU2001(I) = "IndigenousForest" Or LU2003(I) = "ExoticForest" Then

```

```

LU2001(I) = "TreesGrazed"
End If
End If
End If
Next I
For I = 1 To NumObs
If LU2003(I) = "UrbanOpenSpace" And LU2001(I) = "Urban" Then LU2001(I) = LU2003(I)
If LU2001(I) = "UrbanOpenSpace" And LU1996(I) = "Urban" Then LU1996(I) = LU2001(I)
If LU1996(I) = "UrbanOpenSpace" And LU1986(I) = "Urban" Then LU1986(I) = LU1996(I)
If LU1986(I) = "UrbanOpenSpace" And LU1958(I) = "Urban" Then LU1958(I) = LU1986(I)
If LU1958(I) = "UrbanOpenSpace" And LU1940(I) = "Urban" Then LU1940(I) = LU1958(I)
Next I
For I = 1 To NumObs
If LU1958(I) = "PrimePasture" Then LU1958(I) = "IntensiveSheep"
If LU1958(I) = "ExoticPasture" Then LU1958(I) = "ExtensiveSheep"
Next I
For I = 1 To NumObs
If LU1958(I) = "Wetland" Or LU1958(I) = "IndigenousForest" Or LU1958(I) = "ExoticForest" Or LU1958(I)
= "Scrub" Then
    If LU1940(I) = "Grassland" Or LU1940(I) = "Sheep" Or LU1940(I) = "IntensiveSheep" Or LU1940(I) =
"ExtensiveSheep" Or LU1940(I) = "Dairy" Then LU1940(I) = LU1958(I)
End If
Next I
For I = 1 To NumObs
If LU2001(I) = "Water" Then
    LU2003(I) = "Water"
    LU1996(I) = "Water"
    LU1986(I) = "Water"
    LU1958(I) = "Water"
    LU1940(I) = "Water"
End If
If LU2001(I) = "Lake" Then
    LU2003(I) = "Water"
    LU2001(I) = "Water"
    LU1996(I) = "Water"
    LU1986(I) = "Water"
    LU1958(I) = "Water"
    LU1940(I) = "Water"
End If
Next I
For I = 1 To NumObs
If LU2003(I) = "DairyGrazers" Or LU2003(I) = "Beef" Then LU2003(I) = "Cattle"
If LU2003(I) = "Deer" Or LU2003(I) = "Sheep" Or LU2003(I) = "Horses" Or LU2003(I) =
"LowProducingGrassland" Then LU2003(I) = "Sheep"
If LU2003(I) = "RuralRecreation" Or LU2003(I) = "NonGrazedGrass" Then LU2003(I) = "Sheep"
Next I
For I = 1 To NumObs
If LU1958(I) = "Dairy" And LU2003(I) = "Dairy" Then
    LU1986(I) = "Dairy"
    LU1996(I) = "Dairy"
    LU2001(I) = "Dairy"
    LU2003(I) = "Dairy"
End If
Next I
For I = 1 To NumObs
If LU1958(I) = "Dairy" And LU2003(I) = "HighProducingGrassland" Then
    LU1986(I) = "Dairy"

```

```

LU1996(I) = "Dairy"
LU2001(I) = "Dairy"
LU2003(I) = "Dairy"
End If
Next I
For I = 1 To NumObs
If LU2003(I) = "HighProducingGrassland" And LU1958(I) <> "Dairy" Then LU2003(I) = "SheepBeef"
If LU2003(I) = "SheepBeef" And LU2001(I) = "HighProducingGrassland" Then LU2001(I) = "SheepBeef"
If LU2003(I) = "Cattle" And LU2001(I) = "HighProducingGrassland" Then LU2001(I) = "Cattle"
If LU2003(I) = "SheepBeef" And LU2001(I) = "LowProducingGrassland" Then LU2001(I) = "Sheep"
If LU2003(I) = "Cattle" And LU2001(I) = "LowProducingGrassland" Then LU2001(I) = "SheepBeef"
If LU2003(I) = "Dairy" And LU2001(I) = "HighProducingGrassland" Then LU2001(I) = "Dairy"
If LU2003(I) = "Dairy" And LU2001(I) = "LowProducingGrassland" Then LU2001(I) = "SheepBeef"
If LU2003(I) = "TreesGrazed" And LU2001(I) = "Forest" And LU1996(I) = "PrimePasture" Then LU2001(I)
= "TreesGrazed"
If LU2003(I) = "Sheep" And LU2001(I) = "HighProducingGrassland" Then LU2001(I) = "SheepBeef"
If LU2003(I) = "Sheep" And LU2001(I) = "LowProducingGrassland" Then LU2001(I) = "Sheep"
If LU2003(I) = "TreesGrazed" And LU2001(I) = "HighProducingGrassland" Then LU2001(I) =
"TreesGrazed"
If LU2003(I) = "TreesGrazed" And LU2001(I) = "LowProducingGrassland" Then LU2001(I) = "Sheep"
If LU2003(I) = "Lifestyle" And LU2001(I) = "HighProducingGrassland" Then LU2001(I) = "SheepBeef"
If LU2003(I) = "Lifestyle" And LU2001(I) = "LowProducingGrassland" Then LU2001(I) = "Sheep"
If LU2003(I) = "Cropping" And LU2001(I) = "HighProducingGrassland" Then LU2001(I) = "SheepBeef"
If LU2003(I) = "Cropping" And LU2001(I) = "LowProducingGrassland" Then LU2001(I) = "Sheep"
If LU2003(I) = "Forest" And LU2001(I) = "HighProducingGrassland" Then LU2001(I) = "SheepBeef"
If LU2003(I) = "Forest" And LU2001(I) = "LowProducingGrassland" Then LU2001(I) = "Sheep"
If LU2001(I) = "SheepBeef" And LU1996(I) = "PrimePasture" Then LU1996(I) = "SheepBeef"
If LU2001(I) = "Cattle" And LU1996(I) = "PrimePasture" Then LU1996(I) = "Cattle"
If LU2001(I) = "Sheep" And LU1996(I) = "PrimePasture" Then LU1996(I) = "Sheep"
If LU2001(I) = "Dairy" And LU1996(I) = "PrimePasture" Then LU1996(I) = "Dairy"
If LU2001(I) = "Forest" And LU1996(I) = "PrimePasture" Then LU1996(I) = "SheepBeef"
If LU1996(I) = "Cattle" And LU1986(I) = "PrimePasture" Then LU1986(I) = "Cattle"
If LU1996(I) = "SheepBeef" And LU1986(I) = "PrimePasture" Then LU1986(I) = "SheepBeef"
If LU1996(I) = "Cattle" And LU1986(I) = "PastureExotic" Then LU1986(I) = "SheepBeef"
If LU1996(I) = "SheepBeef" And LU1986(I) = "PastureExotic" Then LU1986(I) = "Sheep"
If LU1996(I) = "Dairy" And LU1986(I) = "PastureExotic" Then LU1986(I) = "SheepBeef"
If LU1996(I) = "Dairy" And LU1986(I) = "PrimePasture" Then LU1986(I) = "Dairy"
If LU1996(I) = "Forest" And LU1986(I) = "PastureExotic" Then LU1986(I) = "Sheep"
If LU1996(I) = "Forest" And LU1986(I) = "PrimePasture" Then LU1986(I) = "SheepBeef"
If LU1996(I) = "Sheep" And LU1986(I) = "PrimePasture" Then LU1986(I) = "Sheep"
If LU1996(I) = "Sheep" And LU1986(I) = "PastureExotic" Then LU1986(I) = "Sheep"
If LU2001(I) = "TreesGrazed" And LU1996(I) = "PrimePasture" Then LU1996(I) = "Sheep"
If LU2001(I) = "TreesGrazed" And LU1986(I) = "PrimePasture" Then LU1986(I) = "Sheep"
If LU2001(I) = "TreesGrazed" And LU1986(I) = "PastureExotic" Then LU1986(I) = "Sheep"
If LU1958(I) = "ExtensiveSheep" And LU1986(I) = "SheepBeef" Then LU1986(I) = "Sheep"
If LU1958(I) = "IntensiveSheep" And LU1986(I) = "Sheep" Then LU1986(I) = "SheepBeef"
Next I
For I = 1 To NumObs
If LU2001(I) = "HighProducingGrassland" And LU1996(I) = "PrimePasture" Then LU2001(I) =
"TreesGrazed"
If LU2001(I) = "HighProducingGrassland" And LU1996(I) = "Forest" Then LU2001(I) = "Forest"
If LU2001(I) = "HighProducingGrassland" Then LU2001(I) = LU2003(I)
If LU2001(I) = "LowProducingGrassland" And LU1996(I) = "PrimePasture" Then LU2001(I) = "Sheep"
If LU2001(I) = "LowProducingGrassland" And LU1996(I) = "Forest" Then LU2001(I) = "Forest"
If LU2001(I) = "LowProducingGrassland" Then LU2001(I) = LU2003(I)
If LU1996(I) = "PrimePasture" And LU1986(I) = "PrimePasture" Then LU1996(I) = "SheepBeef"
If LU1996(I) = "PrimePasture" And LU1986(I) = "PastureExotic" Then LU1996(I) = "Sheep"

```

```

If LU1996(I) = "PrimePasture" And LU1986(I) = "PastureExotic" Then LU1996(I) = "Sheep"
If LU1996(I) = "PrimePasture" Then LU1996(I) = LU2001(I)
If LU1986(I) = "PrimePasture" Then LU1986(I) = "SheepBeef"
If LU1986(I) = "PrimePasture" And LU1958(I) = "PastureExotic" Then LU1986(I) = "Sheep"
If LU1986(I) = "PastureExotic" And LU1958(I) = "PrimePasture" Then LU1986(I) = "Sheep"
If LU1986(I) = "PastureExotic" And LU1958(I) = "PastureExotic" Then LU1986(I) = "Sheep"
If LU1986(I) = "PrimePasture" Then LU1986(I) = "Sheep"
If LU1986(I) = "PastureExotic" Then LU1986(I) = "Sheep"
If LU1958(I) = "PastureExotic" Then LU1958(I) = "Sheep"
If LU1958(I) = "PrimePasture" Then LU1958(I) = "Sheep"
If LU1958(I) = "Grassland" And LU1986(I) = "SheepBeef" Then LU1958(I) = "IntensiveSheep"
If LU1958(I) = "Grassland" And LU1986(I) = "Sheep" Then LU1958(I) = "ExtensiveSheep"
If LU1958(I) = "Grassland" Then LU1958(I) = "ExtensiveSheep"
If LU1940(I) = "PastureExotic" Then LU1940(I) = "Sheep"
If LU1940(I) = "PrimePasture" Then LU1940(I) = "Sheep"
If LU1940(I) = "Grassland" Then LU1940(I) = "Sheep"
Next I
For I = 1 To NumObs
If LU1940(I) = "RLTS" Then LU1940(I) = "Forest"
If LU1958(I) = "RLTS" Then LU1958(I) = "Forest"
If LU1986(I) = "RLTS" Then LU1986(I) = "Forest"
If LU1940(I) = "SheepBeef" Then LU1940(I) = "Sheep"
If LU1940(I) = "Lake" Then LU1940(I) = "Water"
If LU1958(I) = "Lake" Then LU1958(I) = "Water"
If LU1986(I) = "Lake" Then LU1986(I) = "Water"
If LU1996(I) = "Lake" Then LU1996(I) = "Water"
If LU2001(I) = "Lake" Then LU2001(I) = "Water"
If LU2003(I) = "Lake" Then LU2003(I) = "Water"
Next I
For I = 1 To NumObs
If LU2001(I) = "Urban" And LU2003(I) = "UrbanOpenSpace" Then LU2001(I) = "UrbanOpenSpace"
If LU1996(I) = "Urban" Then
    If LU2001(I) = "UrbanOpenSpace" Or LU2003(I) = "UrbanOpenSpace" Then LU1996(I) =
"UrbanOpenSpace"
    End If
If LU1986(I) = "Urban" Then
    If LU1996(I) = "UrbanOpenSpace" Or LU2001(I) = "UrbanOpenSpace" Or LU2003(I) =
"UrbanOpenSpace" Then LU1986(I) = "UrbanOpenSpace"
    End If
If LU1958(I) = "Urban" Then
    If LU1986(I) = "UrbanOpenSpace" Or LU1996(I) = "UrbanOpenSpace" Or LU2001(I) =
"UrbanOpenSpace" Or LU2003(I) = "UrbanOpenSpace" Then LU1958(I) = "UrbanOpenSpace"
    End If
If LU1940(I) = "Urban" Then
    If LU1958(I) = "UrbanOpenSpace" Or LU1986(I) = "UrbanOpenSpace" Or LU1996(I) =
"UrbanOpenSpace" Or LU2001(I) = "UrbanOpenSpace" Or LU2003(I) = "UrbanOpenSpace" Then
LU1940(I) = "UrbanOpenSpace"
    End If
Next I
For I = 1 To NumObs
If LU2001(I) = "Urban" Or LU2001(I) = "UrbanOpenSpace" Then
    If LU2003(I) <> "Urban" And LU2003(I) <> "UrbanOpenSpace" Then LU2001(I) = LU2003(I)
End If
If LU1996(I) = "Urban" Or LU1996(I) = "UrbanOpenSpace" Then
    If LU2001(I) <> "Urban" And LU2001(I) <> "UrbanOpenSpace" Then LU1996(I) = LU2001(I)
End If
If LU1986(I) = "Urban" Or LU1986(I) = "UrbanOpenSpace" Then

```

```

    If LU1996(I) <> "Urban" And LU1996(I) <> "UrbanOpenSpace" Then LU1986(I) = LU1996(I)
End If
If LU1958(I) = "Urban" Or LU1958(I) = "UrbanOpenSpace" Then
    If LU1986(I) <> "Urban" And LU1986(I) <> "UrbanOpenSpace" Then LU1958(I) = LU1986(I)
End If
If LU1940(I) = "Urban" Or LU1940(I) = "UrbanOpenSpace" Then
    If LU1958(I) <> "Urban" And LU1958(I) <> "UrbanOpenSpace" Then LU1940(I) = LU1958(I)
End If
Next I
For I = 1 To NumObs
If LU2003(I) = "Lifestyle" Then LU2003(I) = "Sheep"
If LU2001(I) = "Lifestyle" Then LU2001(I) = "Sheep"
If LU1996(I) = "Lifestyle" Then LU1996(I) = "Sheep"
If LU1986(I) = "Lifestyle" Then LU1986(I) = "Sheep"
If LU1958(I) = "Lifestyle" Then LU1958(I) = "Sheep"
If LU1940(I) = "Lifestyle" Then LU1940(I) = "Sheep"
Next I
For I = 1 To NumObs
If LU1940(I) = "Dairy" Or LU1940(I) = "SheepBeef" Or LU1940(I) = "Cattle" Then LU1940(I) =
"IntensiveSheep"
If LU1958(I) = "SheepBeef" Or LU1958(I) = "Cattle" Then LU1958(I) = "IntensiveSheep"
Next I
For I = 1 To NumObs
If LU1996(I) = "Sheep" Or LU1996(I) = "SheepBeef" Or LU1996(I) = "Cattle" Or LU1996(I) =
"ExoticForest" Then
    If LU2001(I) = "IndigenousForest" Or LU2001(I) = "Scrub" Then LU1996(I) = LU2001(I)
End If
Next I
For I = 1 To NumObs
If LU1986(I) = "Sheep" Or LU1986(I) = "SheepBeef" Or LU1986(I) = "ExoticForest" Then
    If LU1996(I) = "IndigenousForest" Or LU1996(I) = "Scrub" Then LU1986(I) = LU1996(I)
End If
Next I
For I = 1 To NumObs
If LU1958(I) = "Sheep" Or LU1958(I) = "IntensiveSheep" Or LU1958(I) = "ExtensiveSheep" Or LU1958(I)
= "ExoticForest" Then
    If LU1986(I) = "IndigenousForest" Or LU1986(I) = "Scrub" Then LU1958(I) = LU1986(I)
End If
Next I
For I = 1 To NumObs
If LU1940(I) = "Sheep" Or LU1940(I) = "IntensiveSheep" Or LU1940(I) = "ExtensiveSheep" Or LU1940(I)
= "ExoticForest" Then
    If LU1958(I) = "IndigenousForest" Or LU1958(I) = "Scrub" Then LU1940(I) = LU1958(I)
End If
Next I
End Sub

```

## 9. References

- Alexander, R.B.; Elliott, A.H.; Shankar, U.; McBride, G.B. (2002). Estimating the sources and transport of nutrients in the Waikato River Basin, New Zealand. *Water Resources Research* 38(12): 1268, doi:10.1029/2001WR000878, 2002.
- Burger, D.F.; Hamilton, D.P.; Hall, J.A.; Ryan, E.F. (2007). Phytoplankton nutrient limitation in a polymictic eutrophic lake: community versus species-specific responses. *Archiv fur Hydrobiologie* 169(1): 57-68.
- Fish, G.R. (1975) *Lakes Rotorua and Rotoiti, North Island, New Zealand: their trophic status and studies for a nutrient budget*. Fisheries Research Bulletin 8. Ministry of Agriculture & Fisheries, Wellington.
- Hoare, R.A. (1980). The sensitivity to phosphorus and nitrogen of Lake Rotorua, New Zealand. *Progress in Water Technology* 12: 897-904.
- Hoare, R.A. (1984). Nitrogen and phosphorus in Rotorua urban streams. *New Zealand Journal of Marine & Freshwater Research* 18: 451-454.
- John, P.; Lock, M.A. (1977). The spatial distribution of groundwater discharge into the littoral zone of a New Zealand lake. *Journal of Hydrology* 33: 391-395.
- Livestock Improvement Corporation (2007). *Dairy statistics 2005-2006*. [www.lic.co.nz/pdf/dairy\\_stats/2006\\_DAIRYSTATISTICS05-06LR.pdf](http://www.lic.co.nz/pdf/dairy_stats/2006_DAIRYSTATISTICS05-06LR.pdf)
- Morgenstern, U.; Reeves, R.; Daughney, C.; Cameron, S.; Gordon, D. (2005). Groundwater age and chemistry, and future nutrient loads for selected Rotorua lakes catchments. GNS Science Report 2005/00. Geological & Nuclear Sciences, Lower Hutt.
- Morgenstern, U.; Gordon, D. (2006). Prediction of Future Nitrogen Loading to Lake Rotorua. GNS Science Report 2006/10. Geological & Nuclear Sciences, Lower Hutt.
- Palliser, C.; Rutherford, J.C. (2009) Agricultural statistics and land cover/use maps for Rotorua. NIWA Client Report: HAM2009-018. February 2009.
- Pang, L.; Close, M.; Sinton, L. (1996). Protection zones of the major water supply springs in the Rotorua district. ESR Report No. CSC 96/7. Institute of Environmental Science and Research, Christchurch. 77 p.



- Ray, D.; Rutherford, J.C. (2004) Estimated residence times in the Rotorua land treatment system. Letter to A. Vosloo, Rotorua District Council. March 2004.
- Rucinski, D.; Wadhwa, S.; Rutherford, J.C. (2006). ROTAN Users Guide – Version 1. NIWA Technical Report. July 2006.
- Rutherford, J.C.; Pridmore, R.D.; White, E. (1989). Management of phosphorus and nitrogen inputs to Lake Rotorua, New Zealand. *Journal of Water Resources Planning & Management* 115(4): 431-439.
- Rutherford, J.C. (2003). Lake Rotorua Nutrient Load Targets. NIWA Client Report HAM2003-155. Hamilton.
- Rutherford, J.C.; Tait, A.; Palliser, C.C.; Wadhwa, S.; Rucinski, D. (2008). Water balance modelling in the Lake Rotorua catchment. NIWA Client Report HAM2008-048. Hamilton.
- Smeeton, D.; Ledgard, S.F. (2007). Rotorua Lakes Catchment Project: Nitrogen (N) leaching calculations: Project Overview. Unpublished AgResearch Report. Prepared for Federated Farmers, Dexcel, Dairy InSight. August 2007.
- Stewart, M.K.; Morgenstern, U. (2001). Age and source of groundwater from isotope tracers. In: *Groundwaters of New Zealand*. M.R. Rosen and P.A. White (eds). New Zealand.
- White, E.; Law, K.; Payne, G.W.; Pickmere, S. (1977). Nutrient demand and availability among planktonic communities – an attempt to assess nutrient limitation to plant growth in 12 central volcanic plateau lakes. *New Zealand Journal of Marine and Freshwater Research* 19: 49-62.
- White, P.A.; Cameron, S.G.; Kilgour, G.; Mroczek, E.; Bignall, G.; Daughney, C.; Reeves, R.R. (2004). Review of groundwater in the Lake Rotorua catchment. Client Report 2004/130. August 2004. Geological & Nuclear Sciences, Taupo.
- White, P.A.; Zemansky, G.; Kilgour, G.N.; Wall, M.; Hong, T. (2007). Lake Rotorua groundwater and Lake Rotorua nutrients. Phase 3 science programme technical report. Client Report 2007/220. September 2007. Geological & Nuclear Sciences, Taupo.
- Wilcock, R.J.; Monaghan, R.M.; Quinn, J.M.; Campbell, A.M.; Thorrold, B.S.; Duncan, M.J.; McGowan, A.W.; Betteridge, K. (2006). Land-use impacts and

water quality targets in the intensive dairying catchment of the Toenepi Stream, New Zealand. *New Zealand Journal of Marine & Freshwater Research* 40: 123-140.

Williamson, R.B.; Smith, C.M.; Cooper, A.B. (1996). Watershed riparian management and its benefits to a eutrophic lake. *Journal of Water Resources Planning and Management* 122: 24-32.

Woodford, K.; Nicol, A. (2005) A re-assessment of the Stock Unit System. MAF Information Paper No: 2005/02. [www.maf.govt.nz/mafnet/index.htm](http://www.maf.govt.nz/mafnet/index.htm).